

VOLUME 11
MARCH 2010

▶▶▶▶ VISION ▶ AUTOMATION ▶ CONTROL ◀◀◀◀

1

INSPECT

D 30 122 F



Factory Automation

Part Identification and Traceability

Quality Control on the Factory Floor

Camera Selection and Interfaces



 **Leuze electronic**

the **sensor** people

PARTNER OF:



GIT VERLAG

A Wiley Company

www.inspect-online.com

Get more VISION

DALSA's Next Generation Smart Camera Technology

BOA is a powerful, inexpensive and ruggedized optical inspection solution for the factory floor.



Ideal for Color/Mono applications:

- Packaging
 - Bottle cap color and label confirmation
- Pharmaceutical
 - Verify pill count and color in blister pack
- Automotive
 - Inspect color or texture of interior parts
 - Verify order of color wires in harness

BOA's tiny form factor and easy mounting capabilities allow it to integrate easily into existing production lines, machinery or moving equipment. In addition, with an IP67 rating, BOA is ready for deployment in harsh or washdown factory environments without the need for costly protective enclosures.

Embedded point-and-click software - easy to use & nothing to install.

Multiple processing engines combine DSP, FPGA and CPU technologies.

Capture the power of DALSA

Download your BOA product brochure here: www.dalsa.com/boac/i3

DALSA

Success Factors

According to Thilo Brodtmann, Managing Director of VDMA Robotics + Automation, automation technology is and remains a sunrise industry (see also commentary on p. 6). Those offering production-related solutions that meet today's challenges will succeed, he says.

Solutions for the tasks from the broad area of factory automation is the focus topic of this INSPECT issue in front of you: from robot automation via quality control to product traceability. One common denominator of all these solutions is that at the end of the chain there is one link making sure that what was planned actually works: in practice, on the factory floor, at all circumstances, reliably. In many a successful application you'll find on the following pages this link is the system integrator.

For David Dechow, Aptúra (see also our Visionaries interview, p. 56) a typical system integrator is described by small team, high level of technical expertise, and low level of sales capacity. During the System Integrator Panel at this year's AIA Business Conference he stated that machine vision integration is a difficult and low-profit business. Markus Tarin, Movimed, even floated the idea that it might prove economically worthwhile to switch from system integration to product sales. His calculation example showed that the profit would be the same and he could axe his project engineers (however, his final conclusion was a decisive "no"). For Peter Tang, ATS Automation, the recipe for success for a system integrator lies in the paradigm "The customer is always right." System integration: a tough life, a miserable business even. A life made even tougher by high, sometimes unrealistically high, customer demands and the marketing machines of the product suppliers suggesting said customers that a solution is to be had for the price of a component. Everybody with system integration experience under their belt would subscribe to this description. But why is that so? Are we talking market laws here?

Maybe the system integrator himself has to take some responsibility for the situation he finds himself in. High level of technical expertise and low level of

sales capacity, says Dechow. That is right to the point. Is it really surprising then that the integrator's own concerns go unnoticed, that the integrator's own message remains unheard? Right, puzzling out ever new solutions for ever new technical challenges has to be in one's DNA, and the motivation to make system integration your career is certainly rather the technical challenge and the variety of tasks, projects and customer industries than the concept of getting rich. However, one does not have to elevate this to a creed, or make an art out of it. Marketing on the system integrator's behalf would help the customer understand what is important, which expectations are reasonable, and what they themselves can and must contribute to a successful factory automation solution. Professional sales on the other hand is the basis for economic success. This holds also true for the "product" system integration.

According to Brodtmann we will see that in the future it is not the size of a company that matters, it is much more the speed and flexibility it owns to adapt to markets that change at an ever faster pace. To get there we need smart automation technology, and for this we need dedicated system integrators that are not only technically skilled but also economically successful.

By the way, quite a few of these companies are listed in our data base at www.inspect-online.com/buyers-guide.

We hope that you will enjoy the success stories of this issue.

Gabriele Jansen
Publishing Director INSPECT



Photonfocus CMOS Kameras

Photovoltaik und Machine Vision

Photonfocus entwickelt CMOS-Sensoren und Kameras mit herausragenden Features auf Sensor-Ebene.



NEU

■ EL1 Elektrolumineszenz

Die Photonfocus EL1-D1312-160-CL ist eine ungekühlte CMOS-Kamera zur Prüfung von Solarzellen und Solarmodulen.

1312 x 1082 Pixel
hohe Empfindlichkeit im NIR
kurze Belichtungszeit ca. 400 ms
z.B. bei Bestromung mit 4 A
optimal für Offline- und Inline-Prozesse

■ D1312 Serie für Bildverarbeitung

Der neue 1,4 Megapixel Sensor mit der Empfindlichkeit und Qualität eines CCDs

1312 x 1082 Pixel, 8,0 µm
169 Bilder/s bei voller Auflösung
hohe Empfindlichkeit 350 bis 1100 nm (NIR)
GigE Vision und Camera Link

■ Umfangreiche Features

LinLog für 120 dB Kontrast, Multiple-ROI, 3x3 Konvolver, LUTs, 12 Bit, Temperatursensor und vieles mehr

■ Low-Cost Versionen

gleiche Auflösung und Geschwindigkeit, beschränkt auf die wichtigsten Features für kostenkritische Anwendungen

AUTOMATICA

München, 8. bis 11. Juni 2010
Halle B2 — Stand 302

RAUSCHER

Telefon 0 8142/4 48 41-0 · Fax 0 8142/4 48 41-90
eMail info@rauscher.de · www.rauscher.de

TOPICS

- 003 Editorial**
Success Factors
Gabriele Jansen
- 005 Preview**
- 006 Viewpoint**
Commentary on the Situation of the Industry
Thilo Brodtmann
- 006 Online**
- 008 News**
- 011 Event Calendar**

COVERSTORY

- 012 Snapshot**
Reliable Reading of Barcodes
and Data Matrix Codes in Motion
Werner Partl

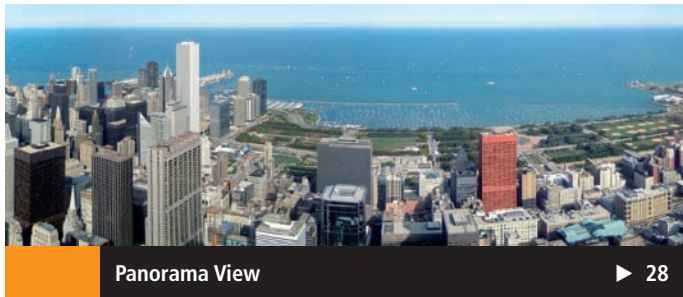

TOPICS

- 014 Machine Vision China**
Established Machine Vision Show in China's Expo City
- 014 VTX Birmingham**
Platform for Machine Vision in UK and Ireland
- 015 Hannover Messe**
"Efficiency – Innovation – Sustainability"
- 016 From Camera Parameters to World Coordinates**
Image Processing Basics: Camera Models
Prof. Dr. Christoph Heckenkamp
- 047 Poll**
- 056 Visionaries**
Interview with David Dechow, President of Aptura
Machine Vision Solutions
- 058 Index & Imprint**

VISION

- 020 On the Fast Lane**
The New Super High-bandwidth Interface Standard: CoaXPress
Colin Pearce
- 024 The Right Choice**
Key Questions for Camera Selection
Nathan Cohen
- 026 Does GigE Vision Make Life Really Easier for the End User?**
Optimal Customer Support through GenICam
Daniel Seiler
- 028 Panorama View**
360 Degree View Ensures Efficient Part Inspection
Claudio Sedazzari
- 030 Everlasting Marking – Reliable Identification**
Reliable Decoding of Dot-marked Signs Even on Challenging Surfaces
- 033 Products**

AUTOMATION

- 037 Ensuring Competitiveness through Machine Vision**
Leading Edge 3D Bin Picking Solution for the Casting Industry
Thor Vollset
- 039 Surface Inspection in Real-time**
Inspection Solutions for Online Quality Control of Castings
Thomas Simon
- 040 Painless Puncture**
Optical Quality Control of Infusion Sets
Martin Schumacher

AUTOMATION

042 Fresh from the Oven

Inspection of Technical Ceramics in Furnace Processes
Christian Wölz

044 Found Despite the Camouflage

Layout Independent Fault Detection of Circuit Boards by AOI Systems with Angled-view Inspection
Jens Kokott

047 Products

CONTROL

048 Rotating Tubes

Length and Speed Measurement for Non-contact Quality Inspection of Tubes
Dr. Heinrich Steger

050 Good Quality?

InGaAs Image Sensor Hybrids for Industrial Applications
Christian Lochmann

052 In the Accelerator

Visual Control of Welding Processes
Oliver Stoll

054 Mastering Challenging Requirements

Accuracy of Fuselage Panel Machining Is Ensured by 3D Laser Scanner
Christophe Gabeau

055 Products

Preview



Look forward to our special on "Total Quality" and the following topics of our next issue:

- Trade show pre-view Control 2010
- Optical Metrology Basics: Radiometric Values
- Technology Focus Optical Coordinate Measurement
- Automotive: Paint Inspection, 3D Tyre Inspection, Gap&Flush Measurement
- Quality Control: OLEDs, Brake Discs, Infusion Sets
- 3D Inline Surface Control and 3D Metrology
- High Speed Process Analysis, Terahertz Quality Control, Micro Lenses
- Product Focus Microscopy/Topography
- New Camera Interface HS-Link
- Interview with Dr. Ralf Christoph, CEO Werth Messtechnik

and much more



DIMENSIONELLES MESSEN



OPTISCHE MIKROMETER

- Messbereiche bis 100 mm
- Grenzfrequenz bis 100 kHz
- Auflösung $< 0,1 \mu\text{m}$
- Reproduzierbarkeit $< 1 \mu\text{m}$
- Messung von Durchmesser, Spalt, Breite und Position



CONTROLLER ZUR DIMENSIONSMESSUNG

- Umfassende Verrechnungsfunktionen
- Für digitale und analoge Sensorsignale
- Automatische Sensorerkennung
- Sehr hohe Verarbeitungsgeschwindigkeit
- Echtzeitfähig

www.micro-epsilon.de

MICRO-EPSILON Messtechnik
94496 Ortenburg · Tel. 0 85 42/168-0
info@micro-epsilon.de

Hannover Messe
19.04.-23.04.2010
Halle 8 / Stand D14



We've researched the Web for you and found this:

www.yet2.com

■ yet2.com provides a platform to post and search for new technologies. You can search here for a technology addressing a demand in your production or complementing your product portfolio. You can also post a technology or a patent that you would like to licence out. The online IP licensing marketplace, founded in 1999 to promote open innovation, technology transfer, intellectual property and patent exchange, now has over 120,000 registered users. To check it out you might want to search for "camera". About 60 entries pop up, including "Automated, in-process method for surface contamination inspection of panels" or "Camera moving apparatus for surveillance camera."

www.data.gov

■ The purpose of data.gov is to increase public access to high value, machine readable datasets generated by the Executive Branch of the United States Federal Government. Easy access is provided by the so-called tool catalogues, pre-selected data sets organized according to topics as, e.g., product recalls, government research spending and results, or the GCMD database which holds more than 30,000 descriptions of Earth science data sets and services covering all aspects of Earth and environmental sciences.

www.inspect-online.com

■ The INSPECT website provides news from the machine vision and optical metrologies industries, updated on a daily basis. For bilingual readers it is very worthwhile to check out both language versions as they provide different sets of data. The Events section features a very comprehensive list of international events with a focus on the vision technologies.

www.tinker.com

■ Tinker is a new service that helps you stay on top of your favorite events by showing you the latest buzz from Twitter for the topics of your choice.

www.wolframalpha.com

■ Wolfram Alpha is an answer engine (as opposed to a search engine), an online service that answers factual queries directly by computing the answer from structured data, rather than providing a list of documents or web pages that might contain the answer as a search engine would. Wolfram Alpha is also capable of responding to natural-language fact-based questions such as: „Where was Nelson Mandela born?“ The answer is not only given with Mthatha, Eastern Cape, South-Africa, but you also learn about the city population, the current local time and weather, get a satellite picture of the region and basic information about cities in the vicinity.

Feel free to send us your online favorites to contact@inspect-online.com

VIEWPOINT

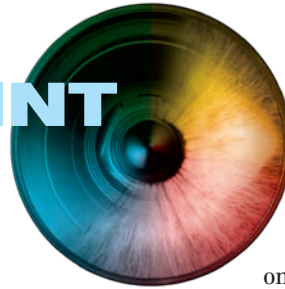

Commentary on the Situation of the Industry

The manufacturers of robotics and automation start the new year with careful optimism. The last months have seen a leveling out of incoming orders. More and more, new enquiries are being received, after a period of stagnation on a very low level for some time. Projects that had been put on ice due to the crisis are again on the agenda – but it is still uncertain what plans will and what plans will not actually see the light of day. One major challenge is in some cases the financing of a project, where customers increasingly tend to shift the burden onto their suppliers. A positive development, however, is that many companies thrive to achieve better products by using intelligent processes to improve on customer satisfaction. The increased use of automation technology is key to this development.

Against this background, I expect that in 2010 a turnover growth by 5% to € 6.4 billion is indeed possible. After the industry had to cope with a slump bringing it back to the turnover figures of the year 2002, we will need some years of continuous growth to reach again the figures achieved in 2007, leave alone the record results obtained in 2008, which in every respect was extraordinary and already marked by the effects of an overheated market. I am quite confident that in the medium term, demography, the global competitive edge and the technologies that ensure an energy-efficient and environmentally friendly production will further promote automation.

Automatica from June 8 to 11, 2010 surely will in this respect become a pace-maker for new investments in customers' industries.

The question is, of course, from which regions the effects stimulating the economy will mainly come. Although the European market has picked up somehow during the last months, it does not display the same momentum as the markets in the Far East do. Increasingly the impetus will be received from China, Korea

and other South East Asian countries. To prevail on the Asian market in particular, speed is key: consumers there incessantly expect new product generations – even for products that technology-wise are still totally up to date. Intelligent automation technology facilitates dynamic management of the manifold variants that is still economically controllable.

Society has developed a strong sense for energy efficiency and careful use of resources. The initiative „Green Automation“ that we have launched will demonstrate how automation technology contributes to energy efficient production and acts as an enabler for green products, at that. In this context, it is crucial that also supply management takes into account life cycle costs of production means. We will approach this topic proactively, too.

Overall, automation technology is and remains a sunrise industry. Those who offer production-related solutions that meet today's challenges will succeed. In the future, we will see that it is not the size of a company that matters, it is much more the speed and flexibility it owns to adapt to markets that change at an ever faster pace.



Thilo Brodtmann
Managing Director of VDMA
Robotics + Automation
www.vdma.com/r+a

FLEA 3

ULTRA-COMPACT FIREWIRE AND GIGE CAMERAS

Software and Support

Image acquisition software for Windows and Linux at no extra charge, and worldwide support response within 24 hours



Ultra-Compact

29 x 29 x 30 mm cast metal case with C-mount lens holder and sensor dust protection system



On-Board Memory

32 MByte frame buffer, 1 MByte non-volatile flash for data storage, and 2 user configuration sets



Sony® CCD Sensor

Eight CCD models, mono or color; VGA at 120 FPS to 5 Mpixel at 8 FPS



Opto-Isolated GPIO

Programmable interface for external trigger sync, strobe output, and serial port communication

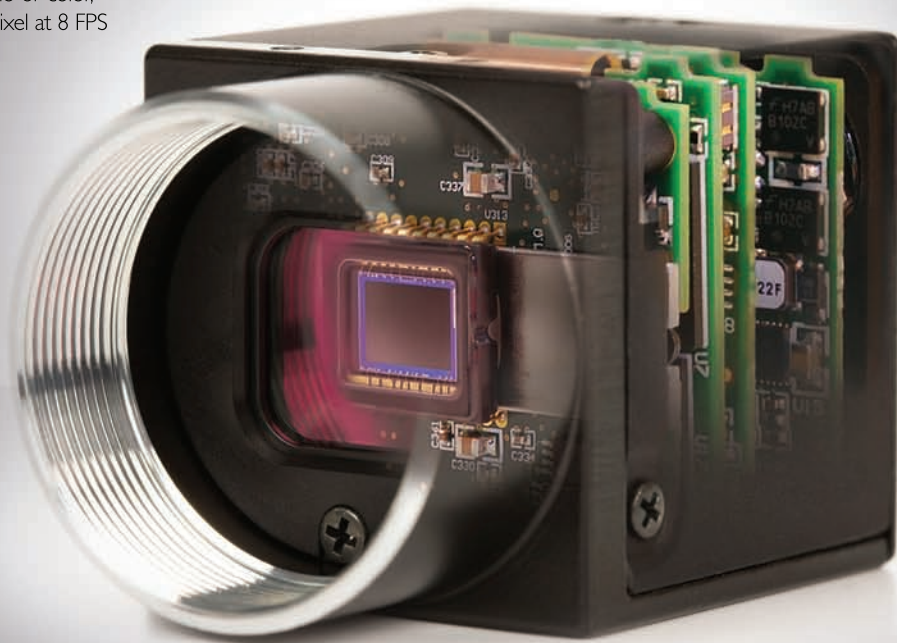

POINT GREY

WWW.FLEA3.COM

GET
PRICING
at FLEA3.COM



Fusion: Networked Sensors for Security and Production

On January 1, 2010 the new Fraunhofer-Institute of Optronics, System Technologies and Image Exploitation was established by fusion of Fraunhofer IITB and FGAN-FOM in Karlsruhe and Ettlingen, Germany. FOM and IITB together possess a unique and continuous spectrum of competence in the area of networked sensor technology. Their know-how ranges from object and atmosphere physics to optics, sensor physics, and image and signal analysis, covering information and knowledge processing, systems technology and anthropomatics as well.

www.iosb.fraunhofer.de



Rusty Ponce de Leon Elected 2010 Chairman of AIA

Rusty Ponce de Leon, President, Phase 1 Technology Corporation, Deer Park, NY, has been elected 2010 Chairman of the Automated Imaging Association (AIA). Ponce de Leon succeeds Mike Cyros, President, Allied Vision Technologies, Inc., Newburyport, MA, whose two-year term as Chairman expired on January 21, 2010. Cyros remains on the AIA Board as Immediate Past Chairman.

"It is a privilege and an honor to serve as Chairman of the AIA Board," said Ponce de Leon. "The organization has had several dedicated and passionate individuals hold this position during the past two decades, and I hope to live up to the legacy they have left."

www.machinevisiononline.org

Linus to Rebrand as Qioptiq

Linus, a member of the Qioptiq Group, announced it is to rebrand as Qioptiq as part of Qioptiq's overall strategy. Despite the very difficult economic environment, Qioptiq announced strong numbers for FY 2009. Qioptiq was able to increase its sales over those of 2008 by 2% at constant exchange rates. Sales were close to US\$ 400 million. Order intakes were significantly above that level and the book-to-bill ratio for 2010 is close to 1.2. In addition, Qioptiq maintained profitability at a similar level to 2008 and is strongly cashgenerative at the operating level.

www.linus.de, www.qioptiq.com



Cognex Corporation Promotes Robert Willett to President and COO

Cognex Corporation has announced the promotion of Robert Willett to President and Chief Operating Officer. Willett will assume these responsibilities in addition to his current role as President of the Modular Vision Systems Division (MVSD), which is the largest operating division of Cognex. He will continue reporting to Dr. Robert J. Shillman, who remains the company's Chairman and Chief Executive Officer.

"After a year and a half with the company, I am more enthusiastic than ever about Cognex," said Willett. "We have a very talented and dedicated team, a great pipeline of products, and new business partnerships that will help us bring those products to more users and more markets around the world. As the global economy recovers, Cognex is in a very strong position to increase its share in the machine vision and industrial ID markets, and I look forward to leading the Cognex teams around the world to make that happen."

www.cognex.com

Cooperation Contract: Simulation of CMOS and CCD Image Sensors

Harvest Imaging bvba, Bree, Belgium and Image Engineering, Frechen, Germany, signed a cooperation contract to develop and market a new software tool for the analysis and simulation of image sensor properties. "This tool will be a milestone for manufacturers and system integrators to specify the best sensors for different applications," so Dietmar Wueller, CEO and CTO of Image Engineering. Until now selecting a sensor for an application was based on the experience of the system integrator to interpret the technical specs of a sensor. "With the new tool this experience can be converted into images without even having the sensor," explains Albert Theuwissen, CEO of Harvest Imaging. "This will help engineers to learn faster, to improve the sensor quality by focusing on the right parameters and to find the right sensor much quicker than today."

www.image-engineering.de, www.harvestimaging.com

Strong Fiscal Year for Applied Vision

Applied Vision Corporation recently announced 2009 earnings on target with the company's growth trajectory over the past five years, marking the end of a sound fiscal year with a strong cash reserve position entering 2010. "In better economic times or otherwise, we have never stopped innovating," said Manijeh Novini, Chief Financial Officer and co-founder of Applied Vision. "Our team members have been solving unique machine vision challenges since 1980. As a result, we've led the way for three generations of inspection technology. Today, there are more than 6,000 Applied Vision installations worldwide in more than 30 countries. We have triumphed over recent hard times by continuing what we do best - providing our global client base with the very best technology and customer support in the industry."

www.appliedvision.com

You Know Cognex Vision

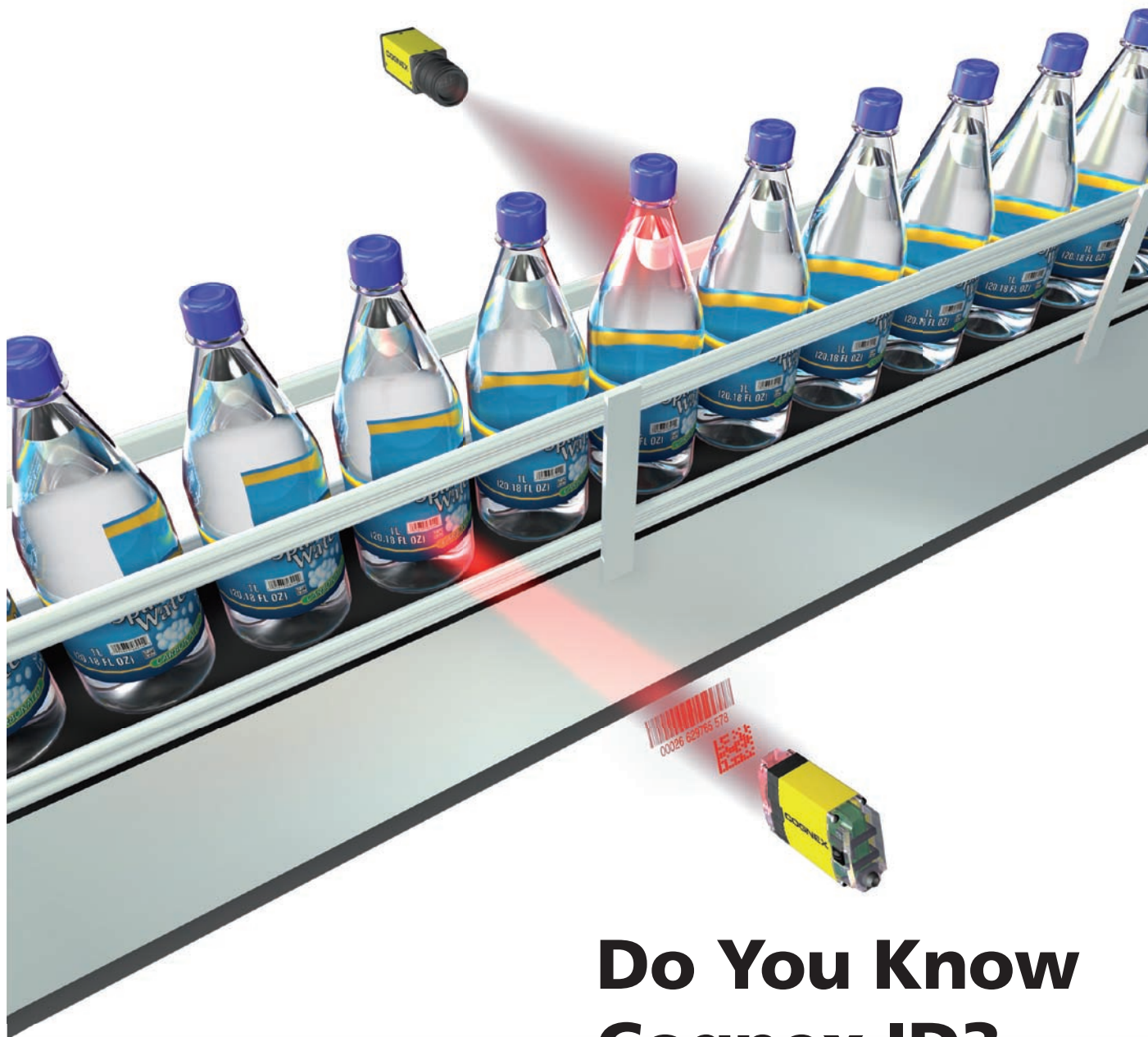

Do You Know Cognex ID?

Quick, powerful, and reliable ID code reading requires innovation that only Cognex® can deliver. Based on our world beating vision technology, DataMan® Industrial ID Readers and Verifiers offer unsurpassed read rates for 1D bar codes and 2D data matrix codes.

DataMan can read virtually any code, even degraded or low-contrast codes on plastic, glass, metal, cardboard, and ceramic packaging and on labels. Simple to use and easy to integrate, Cognex ID provides the perfect answer to all your identification and traceability needs.



Want to know more?
www.cognex.com/plusid

COGNEX



5th China International Machine Vision Exhibition

MV China

3.31-4.2 2010

Shanghai Exhibition Center

International Pavilion

www.mvchina.org
fairsandmore.cn/mvchina

Sponsored by

- Chinese Mechanical Engineering Society (CMES)

Organized by

- Shanghai Tycoon Exhibition Service Company Ltd.

Overseas Organized by

- Automated Imaging Association (AIA)
- Delegation of German Industry & Commerce Shanghai (GIC)
- Japan Industrial Imaging Association (JIIA)

Supported by

- China Machinery Industry Federation (CMIF)
- Verband Deutscher Maschinen- und Anlagenbau (VDMA)
- European Machine Vision Association (EMVA)

Show Hours

- March 31, 2010 09:00 - 16:30
- April 1, 2010 09:30 - 16:30
- April 2, 2010 09:30 - 15:00



NEWS



Torsten Wiesinger Appointed to IDS's Board of Directors

The German machine vision specialist IDS Imaging Development Systems GmbH has appointed Torsten Wiesinger to its Board of Directors. Previously Head of Sales for Europe at IDS, the IT sales specialist now heads up the company's entire sales and marketing operations. Wiesinger joined company founders Jürgen Hartmann and Armin Vogt on the Board of Directors at IDS on February 1, 2010. A graduate in business administration, he has over 15 years track record in IT sales. His career at IDS started seven years ago as a sales representative. In his most recent position as Head of Sales for Europe, he was a major driving force behind the continued growth in the company's international operations.

www.ids-imaging.de

Distribution Agreement for High Speed Cameras

Boulder Imaging, Inc. and Basler Vision Technologies have entered into a distribution agreement for sales and marketing of Basler high-speed cameras. This partnership expands Boulder Imaging's product and solutions offering, coupling the company's powerful Quazar high performance digital video recording and analytic systems with Basler's extensive line of high-speed cameras.

"Basler cameras are widely acknowledged for their superior capabilities, performance, and quality," says Michael Willis, President and COO of Boulder Imaging. "Providing our customers with the very best and the most cost effective imaging solutions for their applications is our focus, and our partnership with Basler greatly expands our ability to deliver exceptional value to our machine vision, scientific and engineering research, and quality control and testing customers."

www.boulderimaging.com,
www.baslerweb.com

Michael Cyros New CEO of North American Operations

Prosilica's integration into the Allied Vision Technologies group is now complete. Effective February 1, 2010, the former Prosilica Inc. with headquarters in Burnaby, BC (Canada) is now incorporated as Allied Vision Technologies Canada Inc. This step completes the integration process of both companies. The new Chief Executive Officer of Allied Vision Technologies Canada Inc. is Michael Cyros, who also heads AVT's subsidiary in the USA, Allied Vision Technologies Inc. Cyros is now in charge of the whole American operations of AVT, which includes the Burnaby, BC R&D and production site as well as the Newburyport, MA sales office.

www.alliedvisiontec.com

GigE Vision 1.2 Released

The GigE Vision camera interface standard has recently been updated and Version 1.2 is now available. Version 1.2 introduces non-streaming device control to the popular standard. It accommodates networked video distribution applications that leverage switched Ethernet client/server video networks. Devices such as GigE Vision-enabled lights will now be automatically recognized by the computers on the network. "Version 1.2 is a major milestone for GigE Vision as it opens the doors for new classes of products beyond the traditional camera. It enables the integration of various types of devices through a common control protocol, greatly simplifying software development for system integrators. This demonstrates the direction GigE Vision is taking to be more than a simple camera interface by providing a complete networking model to machine vision," said Eric Carey, Chair of the GigE Vision Standard Committee and R&D Director at Dalsa Corporation.

www.machinevisiononline.org

Calendar

DATE	TOPIC · INFO
23.–26.03.2010 London, UK	ISE 2010 At Image Sensors Europe the leaders of the image sensors world convene www.image-sensors.com
31.03.–02.04.2010 Shanghai, China	Machine Vision China The largest specialized machine vision exhibition in China www.mvchina.org
16.–17.04.2010 Istanbul, Turkey	EMVA European Machine Vision Business Conference 2010 Annual business conference of the European Machine Vision Association www.emva.org
19.–22.04.2010 Moscow, Russia	Photonica Leading exhibition event of the Russian laser and optical industry www.photonica-expo.com
27.–28.04.2010 Birmingham, UK	VTX Vision Technology Exhibition The leading exhibition for vision technology in UK www.devicelink.com/expo/advuk10/
27.–29.04.2010 Moscow, Russia	VIT Expo VIT Expo Vision & Imaging 2010 is devoted to machine vision www.ruai-interex.ru
04.–05.05.2010 Duisburg, Germany	5th Fraunhofer IMS Workshop: CMOS Imaging – Low-Light Imaging International workshop on CMOS imaging, focus on low-light imaging www.ims.fraunhofer.de
04.–06.05.2010 Cologne, Germany	Euro ID International trade fair and science forum for automatic identification www.euro-id-tradefair.com
04.–07.05.2010 Stuttgart, Germany	Control The world's leading trade fair presents QA solutions with a future www.control-messe.de
25.–27.05.2010 Boston, MA, USA	The Vision Show North America's leading showcase of machine vision and imaging components and solutions www.machinevisiononline.org
08.–11.06.2010 Munich, Germany	Automatica International trade fair for automation and mechatronics automatica-munich.com
15.–18.06.2010 Frankfurt, Germany	Optatec International trade fair for optical technologies, components, systems and manufacturing www.optatec-messe.de
31.08.–02.09.2010 Dresden, Germany	International X-ray CT Symposium Symposium on high-resolution computer tomography www.phoenix-xray.com
13.–16.09.2010 Stuttgart, Germany	Microsys Trade fair for micro and nano technology www.microsys-messe.de
27.–29.10.2010 Beijing, China	Vision China 2010 China international machine vision exhibition and machine vision technology and application conference www.visionchinashow.net
09.–11.11.2010 Stuttgart, Germany	Vision International trade fair for machine vision www.vision-messe.de
09.–12.11.2010 Munich, Germany	Electronica International trade fair for components, systems, applications www.electronica.de
21.–24.03.2011 Chicago, USA	Robots, Vision & Motion Show / ProMat 2011 ProMat 2011 and international robots, vision and motion control show www.promatshow.com

Find these and more events with detailed information at <http://www.inspect-online.com/en/events>

Digitale Kamera? uEye®!



USB uEye®ME

- Kamera im Sensorformat
- Bis 10 Megapixel
- Verschraubbarer USB-Anschluss
- Stabiles Metallgehäuse
- Trigger und Flash
- Große Sensorenauswahl
- Vielfältige Befestigungsmöglichkeiten

Ab jetzt auch mit
HDR-Sensor lieferbar!



USB

Von Boardlevel bis zur IP 65/67 Variante.
Hohe Verfügbarkeit und größtmögliche Flexibilität.



GigE

Ultra-kompakt oder
Realtime Pre-Processing.
Plug & Play GigE-Kameras.

IDS

www.ids-imaging.de

Tel. 07134/96196-0

Snapshot

Reliable Reading of Barcodes and Data Matrix Codes in Motion

The photography of fast motions, like the ones of birds, is an art. In a snapshot of extremely short exposure time, enough light has to be provided to freeze the movement and obtain a sharp image. In the industry, this problem also occurs with fast processes, like reading and verifying of codes in motion. The engineers at Leuze electronics found a solution to this and thus provide the user with a range of new possibilities of employing code readers.

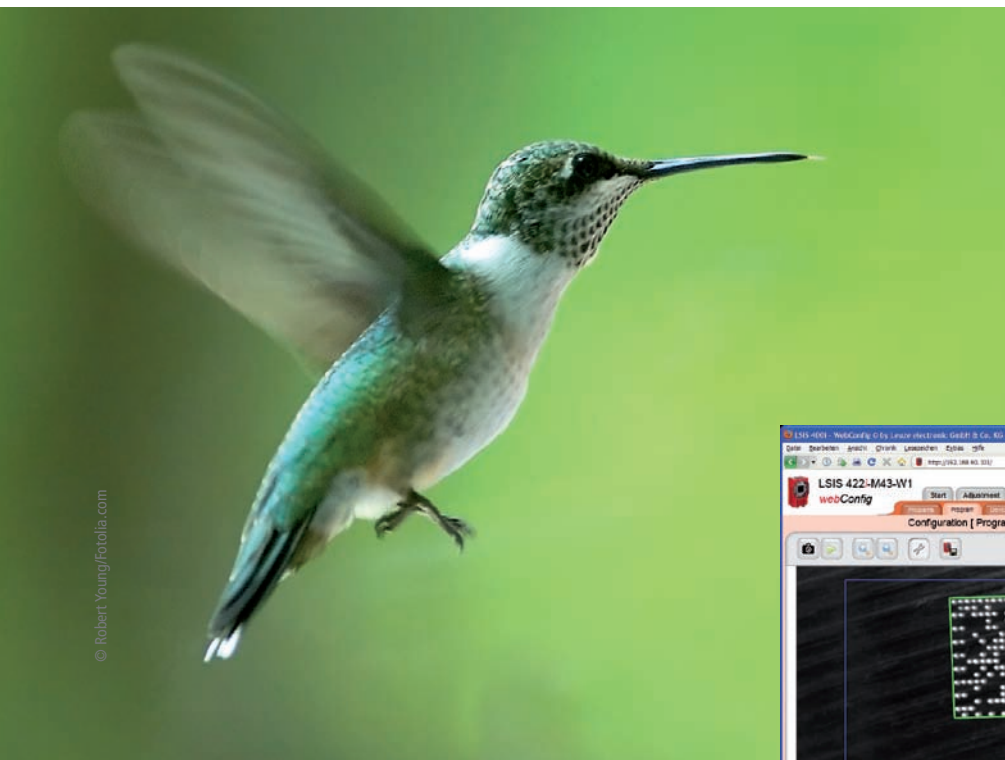

Wing movement of insects or birds: This motion is too rapid to be seen by the human eye. Capturing just this movement with a camera is the obsession of nature photographer Stephen Dalton. He had his breakthrough in the seventies, when he was the first who captured an absolutely clear and sharp image of an insect in free flight. It had taken him several years of experiments to prepare and tune the camera and flash units.

But not only in nature, also in industrial applications, e. g. logistic processes, it is necessary to capture fast motions. There, the codes of fast moving parts have to be read reliably in order to identify these parts unambiguously. In this case, the exposure time is decisive. In order to capture a sharp image during a

Fig. 1: Via the web-Config user interface, the user can set some parameters on his own to accelerate the read rate

rapid movement, the exposure time must be kept very short. Leuze electronics smart cameras of the LSIS 400i product family permit an exposure time as fast as 54 µs; the resulting images have almost no blurring. A short exposure time, however, means that the amount of incident light is low. As a result, the image tends to be too dark. Leuze provides a solution to this problem: during the short expo-

Leuze Codes

With the LSIS400i smart cameras, Leuze electronic always specifies a combination of three numbers. The first number stands for the product family, with its design and performance data. For example, the 400 series has a larger housing than the 100 family. The number that follows provides information on the software version. "1" means Blob analysis. With a 41x smart camera, completeness or presence monitoring can be performed. If a "2" appears in the second position, software for code reading is included, as is the case with the new LSIS 422i. The 46x model includes all available software tools.

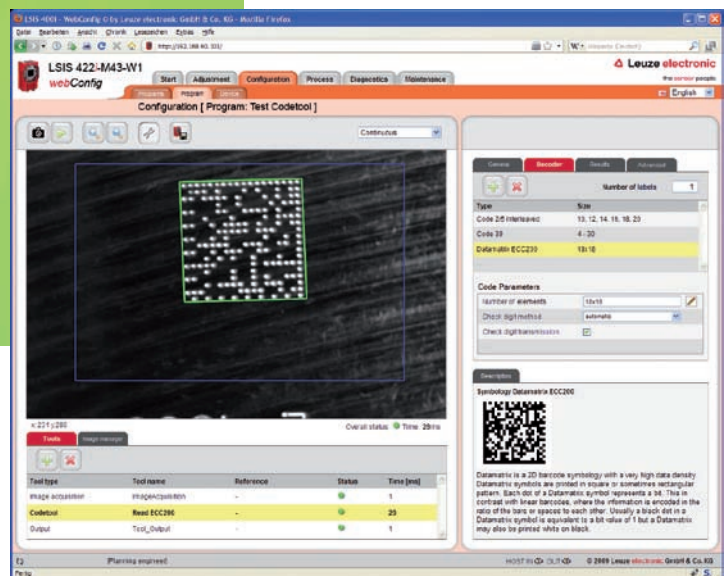

sure time, the LEDs are flashed through the application of a corresponding over-current. The result is an image that is brighter than obtained by comparable devices.

The LSIS 400i Series

The LSIS 400i product family illuminates the field of view very uniform by means

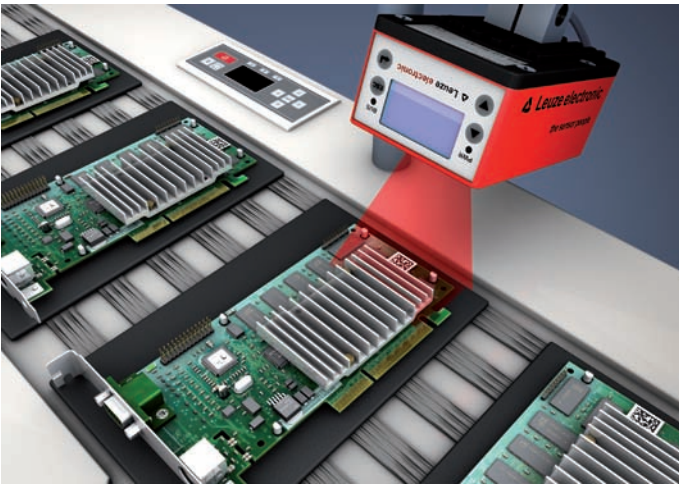

Fig. 2: The code reader LSIS 422i can identify the laser-etched Data Matrix code on this circuit board

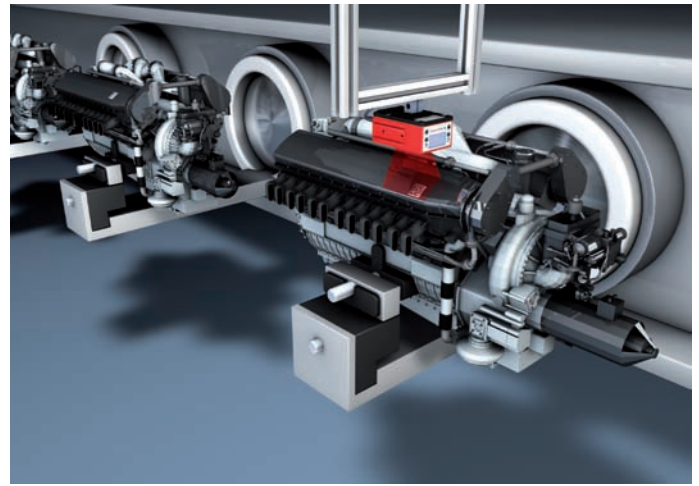

Fig. 3: Directly marked Data Matrix codes, such as on this engine block, can be read by the LSIS 422i: Automobile manufacturers and suppliers benefit from the complete documentation through component traceability

of free-form shapes. This is achieved through the use of a technique in which specially calculated lenses are positioned in front of the LEDs to distribute the point-shaped light of the source very homogeneously on the image field in a rectangular shape. Without these lenses, the circularly arranged LEDs would illuminate the image field inhomogeneously. This, in turn, would make it difficult or even impossible to read the codes or to detect and to analyse objects.

For industrial use, the devices are, in addition to the M12 connection technology, also equipped with a metal housing and glass window and are designed to protection class IP 65 or IP 67. For particularly sensitive areas, such as the food industry, the windows are also available in plastic.

Process communication is by means of eight freely configurable I/O ports, one RS232 interface or via Ethernet. A standard browser allows a user friendly web configuration of the code reader. Additionally, a built-in display shows the reader's status and ensures diagnostic functions.

The Code Reader LSIS 422i

The new addition, the LSIS 422i, offers all of these features as well. It reads not only high-contrast, affixed (printed) barcodes and 2D Data Matrix codes, but also those that are directly marked (laser-etched or dot-peened). If the code is applied on a glossy surface, reflections make reading more difficult. With homogeneous illumination, such as that offered by the Leuze smart cameras, this is not a problem, however. Benefiting from this feature are, above all, the circuit

board and automobile industries, which, in addition to the part number, also need to unmistakably identify individual serial numbers for traceability purposes.

Acceleration of the Reading Process

The respective software is designed in that way, that the user can set some parameters on his own. For example, a pre-filter can be used to define certain code properties in order to accelerate the reading process. If the user knows what type of code is being used, he can set the corresponding properties. With 1D code, the step size of the search can also be increased in order to boost the performance of the camera. In this way, it is possible not only to detect large or small codes, but also to increase the reading speed. Other options for application-specific presettings for one-dimensional codes include read direction and inverted codes. Even if it is the same code, a black code on a white background results in a different image for the camera than a white code on a black background. If it is known that the code is inverted, it is possible to define this in advance in order to save the time that the software would otherwise need to automatically detect the inverted code as such.

Inverted two-dimensional codes can also be read. With these, the reading mode can be set: "fast" for codes of good quality or "robust" for more critical, e.g. directly marked codes. If Data Matrix codes are not the typical squares, but are instead a pattern of holes, the algorithm also detects these so-called dot-peened codes by means of the presetting. Also mirrored codes can be read by the software.

Determining Code Quality

In addition to reading the codes, quality parameters of the read codes can be determined and evaluated. This is particularly useful if the codes will be read later by various types of readers. Thus, it is possible to inspect the quality of the code immediately after printing in order to ensure that the generated code can be reliably read. The user can specify the quality criteria himself and, for example, define a value below which a warning is output. The device can trigger a response not only for the code quality, also during verification. Because the content of the code is known during verification, the read content does not need to be passed on to the control. Digital outputs, which are appropriately set depending on whether the content matches or is different than what is expected, suffice.

► **Author**
Werner Partl,
Product Manager
Machine Vision,
Business Unit Logistics



► **Contact**
Leuze electronic GmbH + Co. KG, Owen,
Germany
Tel.: +49 7021 573 0
Fax: +49 7021 573 199
info@leuze.de
www.leuze.com



Machine Vision China

Established Machine Vision Show in China's Expo City

Now, it is the fifth year for the fair organizer Shanghai Tycoon to arrange the Chinese machine vision show: The China International Machine Vision Exhibition 2010 takes place in Shanghai from March, 31 until April, 2. Last year, 101 exhibitors from 15 countries presented their products on an area of 7,500 m² in the exhibition center. Oversea exhibitors came mainly from Europe, USA and Japan. Last years visitors were mainly Chinese experts and users, professionals and agents of the main institutions and agencies for industrial image processing and identification technologies. As in recent years, the visitors will find a wealth of information on components and pro-

ducts of machine vision as well as on system solutions in the fields of machine vision, identification technologies and measurement systems. On all three days, there are technical seminars parallel to the exhibition, presented by the exhibitors. In order to guarantee the international character of the the fair, Shanghai Tycoon has some co-organizers from overseas including the Machine Vision Associations from Europe, USA and Japan: the European Machine Vision Association EMVA, the Automated Imaging Association AIA and the Japan Industrial Imaging Association JIIA, as well as the GIC, the Delegation of German Industry & Commerce Shanghai. AIA and GIC will

organize the International Pavillon for some of the overseas exhibitors on an area of 150 m². As last year, the EMVA will invite Chinese machine vision users to a presentation and a round tour afterwards to the member companies exhibiting at the show.

► **Contact**

Shanghai Tycoon Exhibition Service Company, Ltd., China
Tel.: +86 21 54661078
Fax: +86 21 54661065
mvchina@shanghaitycoon.com
www.mvchina.org

VTX Birmingham

Platform for Machine Vision in UK and Ireland

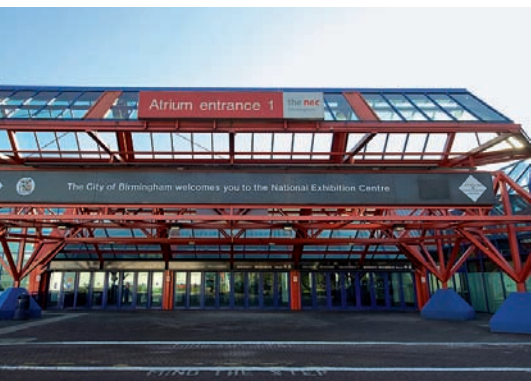

On April 27 and 28, the VTX Vision Technology Exhibition takes place in Birmingham, UK. This fair applies to experts as well as to new users of machine vision technology from UK and Ireland and un-

der the umbrella of Advanced Manufacturing UK it is embedded in a host of other trade shows, like Machine Building & Automation and mtec, an exhibition for sensors and measurement instrumentation. On these two days the visitors can catch up on everything about machine vision systems, software, cameras, identification technology, inspection systems and optical technologies. One day is enough to know everything about the actual branch trends and to get the innovations, says Garry Beard, development engineer at Corus UK. With the cross-industry orientation the show brings users, manufacturers, distributors and system integrators together. The UK Industrial Vision Association UKIVA again invites the trade show visitors to a series of free-

of-charge seminars, this year about "Vision for the Future: Next Generation Solutions for Manufacturing."

► **Contact**

OctoMedia Ltd., London, United Kingdom
Tel.: +44 1622 661363
Fax: +44 1622 661687
advancedmanufacturinguk@cancom.com
www.vtxukshow.com

Hannover Messe

“Efficiency – Innovation – Sustainability”

Better, faster, more effective: Leading-edge technology plays a pivotal role in corporate competitiveness. In order to extend one's lead in their production, visitors can find information about their possibilities on the Hannover Messe. Altogether, with nine leading trade shows the trade fair will be showcasing innovations, developments and technologies from the world of industry from April, 19 until April, 23. In 2010 Hannover Messe once again offers a separate display arena for manufacturers of industrial marking and identification technology and image processing solutions: Identification, Vision & Protection. There, interested visitors find innovations for product marking and identification, product protection and product tracking. With these technologies the efficiency of production, logistics and maintenance is increased and costly errors are eliminated. The field of inspection provides RFID systems, Barcode and DataMatrix-Code readers. Furthermore, in the field of vision, there are presented solutions-oriented image processing systems which can be used in all areas of manufacturing industry. They are invaluable in areas such as quality assurance. Finally, solutions designed to provide protection against industrial piracy are introduced in the arena of product protection. Therefore, this will be a key topic at Hannover Messe 2010 because only with such solutions the ability of businesses can be safeguarded to innovate and compete successfully. This display arena is located right alongside the displays of allied technologies such as production logistics, mechanical and plant engi-

neering, robotics and industrial automation, thus generating valuable knock-on effects for exhibitors and visitors alike.



► Contact

Deutsche Messe, Hanover, Germany
Tel.: +49 511 89 0 · Fax: +49 511 89 32626
info@messe.de · www.hannovermesse.de

Industrielle GigE Komplettlösungen Innovative Gigabit Ethernet Kameras und Netzwerkcomponenten



Die entscheidenden Komponenten für Ihre Applikation

- GigE Vision® Kameras von VGA bis 5 Megapixel
- Flexible Kameraintegration durch industrielle GigE Switche und PoE Injektoren
- Trigger Device zur Steuerung zeitkritischer Prozesse über das Netzwerk
- Komplettlösungen für Power over Ethernet (PoE)
- Zeit- und kostenoptimierte Installation und Wartung

Neugierig geworden?

www.baumer.com/cameras

Baumer

www.baumer.com

From Camera Parameters to World Coordinates

Image Processing Basics: Camera Models



Applications of image processing in robotics or 3D metrology often call for the determination of coordinates for points in real space, the so-called world-coordinates, from the data in the image file. The corresponding calculations are based on a quantitative geometric camera model. In contrast to radiometric models, the signal path is not relevant in this context. A geometric camera model describes the image formation from points in the workspace to pixel coordinates in the data file.

Central Projection

An image of a scene in three-dimensional space taken with a standard lens will be formed in central projection, resulting in warped geometric objects due to perspective distortion. Figure 1 shows an example. All the rectangular stones have the same edge-length in reality, but appear more and more shrunken with increasing distance. In the upper half of figure 2, the situation is described within the so-called “pinhole camera model”, which holds in good approximation for imaging with a standard lens with fixed focal length. The objects in the workspace are drawn on the right hand side of the lens. The detector chip is mounted in the image plane of the

camera, shown on the left hand side of the lens. Two objects with identical dimensions, placed at different distances from the lens, will appear as images of different sizes due to central projection. A sharp image will appear for a single defined working distance only. In practical applications, however, the depth of field usually can be tuned to be sufficiently large by proper choice of the focal length and the f-number. The quantitative relations can be derived from the lower part of figure 2. A point with world-coordinates X_W and Z_W in the working space will be imaged to a point with the sensor-coordinate x_s in the vertical distance b from the centre of the projection. The parameter b is an inter-



Fig. 1: Warping by central projection

nal parameter of the camera model, the image distance, sometimes (but not strictly correctly) denoted as the focal length. As can easily be seen, $X_W/Z_W = x_s/b$. This relation also holds, when the image is blurred. In this situation, the image of a point just grows to a small disk, but the position of this blob remains the same as in the corresponding sharp image within good approximation. In general, a point of interest in the scene will not necessarily be located in the X_W - Z_W -plane shown in figure 2 but may have a world-coordinate Y_W not equal to zero perpendicular to the drawing plane. The corresponding point in the image will have a sensor coordinate y_s not equal to zero. The central projection of a point with the world coordinates X_W, Y_W and Z_W to an image point with the sensor coordinates x_s and y_s is thus described by the following two equations:

$$\begin{aligned} x_s &= -b (X_W/Z_W) \\ y_s &= -b (Y_W/Z_W) \end{aligned} \quad (1)$$

All quantities in these equations have linear units such as millimeter or micrometer. The sensor coordinates x_s and y_s , also measured in millimeters or micrometers, are not yet related with the pixel coordinates of the image in the data file, but are coordinates in the real world, although not in the workspace, but in the image plane of the camera. The pixel-coordinates of the data file have to be linked with real dimensions in the sensor plane by the well-known, precise array cell structure of the detector chip.

GigEvolved



Break through the 90 MB/s barrier. The Prosilica series of GigE cameras offers a sustained data rate of over 120 MB/s and up to 240 MB/s thanks to an innovative, GigE Vision compliant interface. And if you are using multiple cameras on the same bus, you can even control how much bandwidth each camera utilizes. Now that all Prosilica GigE cameras have joined the camera range of Allied Vision Technologies, you have a virtually unlimited selection of sensors and features with a GigE or FireWire interface. See them all at www.alliedvisiontec.com



SEEING IS BELIEVING

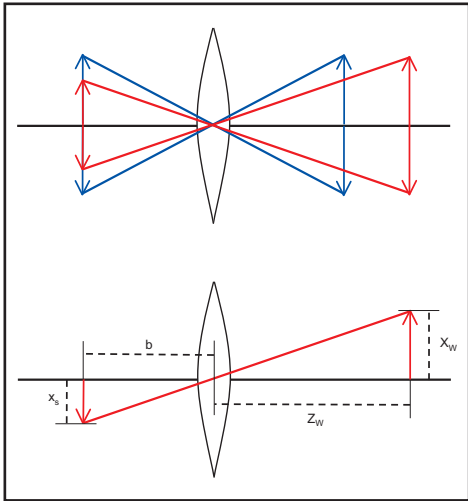

Fig. 2: Central projection in the pinhole-camera model

External and Internal Parameters

Geometric camera models use two different world-coordinate systems. The world-coordinate system of the camera already appeared in figure 2. In this system, a point in the workspace has the world-coordinates X_w, Y_w

and Z_w , with the origin in the projection centre of the lens. The Z_w -axis is directed along the optical axis of the lens. This coordinate system will rotate and move with the camera when the orientation and the position of the camera (the so-called pose) are changed. Usually, however, it will be more convenient to

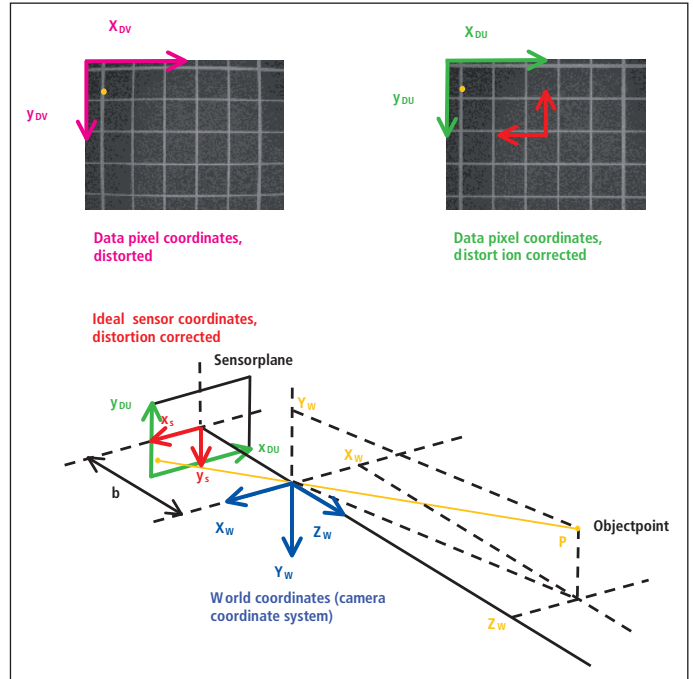

Fig. 3: Coordinate systems for the transformation of world-coordinates to pixel-coordinates in the image data file and the influence of optical distortion

use a second world-coordinate system in the workspace, which may be related to a fixed plane such as a conveyor belt or a tabletop. We denote these world-coordi-

FUJINON
FUJIFILM



**Maximale Qualität.
Minimale Toleranz.**

Fujinon Machine Vision Objektiv
für 3 CCD Kameras.

www.fujinon.de

Medical TV CCTV **Machine Vision** Binoculars

Rüsten Sie Ihre Bildverarbeitung optimal aus. Mit den Präzisionsobjektiven von Fujinon. Die speziell für 3 CCD Kameras entwickelten Objektiv sind bestens abgestimmt auf die Strahlteiler typischer 3 CCD Kameras und zeichnen sich durch eine genaue Farbwiedergabe und minimierte

chromatische Aberration aus. Die Festbrennweiten von 2,8 bis 25 mm erlauben zudem einen großen Einsatzbereich – ob Weitwinkel oder Tele. Und dank des kleinen und leichten Designs lässt sich jedes Modell einfach in Ihr System integrieren. Fujinon. Mehr sehen. Mehr wissen.

nates as (X, Y, Z). This coordinate system may be transformed into the camera coordinate system (X_w, Y_w, Z_w) by two simple operations. The first operation is a translation of the origin of the system of the workspace into the origin of the camera coordinate system, characterized by the three components of the corresponding translation vector. The second operation is a rotation of the coordinate system such that the corresponding axes of the two systems point into the same directions. This rotation may be described by a rotation matrix with three independent parameters. The six degrees of freedom of the orientation and position of the camera in space are thus determined by six parameters, the so-called external (or exterior or extrinsic) camera parameters. The camera model now contains these six external parameters and the image distance as an internal (or interior or intrinsic) parameter.

The final step of the camera model is the connection with the pixel coordinates in the data file. The origin of the pixel coordinate system usually is placed in the upper left corner of the image which will be seen when viewing into the workspace from the position of the camera. The lens will image this point to the lower left corner of the detector chip, now viewed from the workspace back to the camera. Have a look at figure 3 to get a better insight into these somewhat complex geometric relations. The yellow object point has the world coordinates (X_w, Y_w, Z_w) in the blue world-coordinate system of the camera. The coordinate system (X, Y, Z) in the workspace is not drawn to avoid confusion. The object point is imaged to a point in the sensor plane, which will appear in the upper left corner of the image in the data file. To emphasize this point, the upper part of figure 3 contains a view of the computer screen where the data file is displayed. In the lower part, the green coordinate system of the data file is embedded in the sensor plane. In addition to the data file coordinate system (x_D, y_D), the camera model defines the red sensor coordinate system (x_s, y_s). The origin of this system is located at the point where the optical axis hits the detector plane, the so-called principal point. The x- and y-axes of this system are directed parallel to the X_w - and Y_w -axes of the camera world coordinate system. The coordinates x_s and y_s are measured in linear units such as millimeter or micrometer. The first step to get sensor coordinates from pixel coordinates is to shift the ori-

gin of the coordinate system of the data file to the centre point of the sensor. These centred coordinates are then multiplied by the edge lengths S_x and S_y along the x- und y-direction. The result will be sensor coordinates scaled with real-world units. The scaling factors S_x and S_y usually are taken from the data sheet of the camera. Cameras with a digital interface will transfer the data from the sensor into the image data file as they are, whereas with analog cameras the ratio between sampling frequency of the frame grabber and the pixel clock has to be taken into account. Pixel coordinates can be calculated from sensor coordinates according to the following equations:

$$\begin{aligned}x_D &= -x_s/S_x + H_x \\y_D &= -y_s/S_y + H_y\end{aligned}\quad (2)$$

H_x and H_y are the pixel coordinates of the principal point. Cameras designed for industrial image processing usually will have fairly well adjusted sensors, and the principal point will simply be the centre of the chip in good approximation. The number of pixels on the x- and y-axis, respectively, will thus determine the values for H_x and H_y . These parameters, however, may also be treated as further degrees of freedom in the camera model.

Distortion Correction

For real-world applications, an additional modification of the camera model is mandatory, namely, the distortion correction. The well-known workhorses of industrial imaging are simple C-mount or CS-mount lenses, which suffer from considerable optical distortions. An example is shown in the upper left corner of figure 3. The main part of the distortion has rotational symmetry and is a function of the radial distance from the optical axis only. A single parameter κ is sufficient to characterize this relation. One possible modeling uses the following equations:

$$\begin{aligned}x_{DU}^* &= x_{DV}^*/(1+\kappa r_V^2) \\y_{DU}^* &= y_{DV}^*/(1+\kappa r_V^2)\end{aligned}\quad (3)$$

where $r_V^2 = x_{DV}^{*2} + y_{DV}^{*2}$. The parameter κ describes the transformation from undistorted to distorted pixel coordinates in the data file, but with reference to the principal point, marked by the asterisk. In the upper right part of figure 3 the re-

sult of the distortion correction is shown. The red sensor coordinates in figure 3 are thus the ideal, undistorted sensor coordinates, which would appear in the sensor plane by imaging with an ideal, distortion-free lens. The camera model now contains further five internal parameters.

Final Remarks

The camera model described in this article, with six external and six internal parameters, is based on the work of Lenz [1] and Tsai [2], published already in 1987. The numerical determination of the values of these parameters by so-called camera calibration, based on images of calibration targets with reference points at precisely known world coordinates, is mathematically quite complex. Modeling the imaging process in terms of linear algebra with matrix operations will greatly simplify any approach to these methods. Fortunately, there is a lot of literature on this topic with good explanations and documentation [3, 4] for those readers who would like to tackle these interesting problems.

References

- [1] Lenz, R., Informatik-Fachberichte 149: Mustererkennung 1987, p. 212-216, Springer 1987
- [2] Tsai, R. Y., IEEE Journal of Robotics and Automation, Vol. RA-3 (4) 1987, p. 323-344
- [3] Steger, C., Ulrich, M., Wiedemann, C., Machine Vision Algorithms and Applications, Wiley-VCH, Weinheim 2008, p. 180 ff.
- [4] Azad, P., Gockel, T., Dillmann, R., Computer Vision, Elektor, Aachen 2007, p. 73 ff.

► Author

Prof. Dr. Christoph Heckenkamp
Darmstadt University of Applied Sciences
Department of Optical Technology and Machine Vision
heckenkamp@h-da.de
www.fbmn.h-da.de



On the Fast Lane

The New Super High-bandwidth Interface Standard: CoaXPress

Machine vision interface standards and standards in general usually have pros and cons – it is rare to find a technology that ticks all the boxes. CameraLink is simple, relatively fast, but suffers from restricted cable lengths and expensive cabling. GigE Vision has the benefits of low-cost cabling, long cable lengths and no frame grabber needed. However, it is complex, has a relatively low bandwidth and does not have true real-time performance. Firewire and USB 3.0 have similar pros and cons. CoaXPress, however, is a new digital video specification, soon to be a standard, that outperforms other machine vision interfaces in all areas.

CoaXPress is very fast, scalable, supports long cable lengths, provides power over the cable and is relatively simple. When first introduced to the technology, it is hard to believe it is possible: CoaXPress can transmit video data from a camera at 6.25 Gbits/s whilst powering the camera and sending control data back to the camera at 20 Mbits/s – all at the same time and over a single coaxial cable. It is also scalable, so put eight coax cables together, and the data rate available is now 50 Gbits/sec.

Technology Evolution

In the early days of video and image processing, coaxial cable was extensively used – in fact today it is still widely used in many imaging and machine vision systems. The reason of course is that it is very simple to use, low cost, and allows for long cable runs. When digital video arrived on the scene in machine vision in the early 1990s, cameras started providing digital outputs on wide busses using Low Voltage Differential Signaling (LVDS). This spawned a variety of incompatible cameras, cables and frame grabbers. Meanwhile the trend towards high speed serial links was starting in other industries and was first seen in machine vision with the CameraLink standard (around 2000) which, although it still uses a multi-core cable, does perform a 7:1 serialization of the data onto each line. Over the last ten years the trend towards high-speed serial interfaces has been gathering pace in many areas – particularly in the broadcast and communications industry. For example, we can now



© 2009 George Yi, All Rights Reserved.

BNC connector and lead
(Courtesy Active Silicon)



Find the
difference!



Best Players play at VISION

VISION has established itself as the world's most important trade fair for machine vision. It is therefore almost a matter of course that the international who's who of the machine vision industry meet year after year in Stuttgart.

And why is that? Look for yourself!

www.vision-messe.de

VISION
2010

**23rd International Trade
Fair for Machine Vision**

Messe Stuttgart, 9 – 11 November 2010

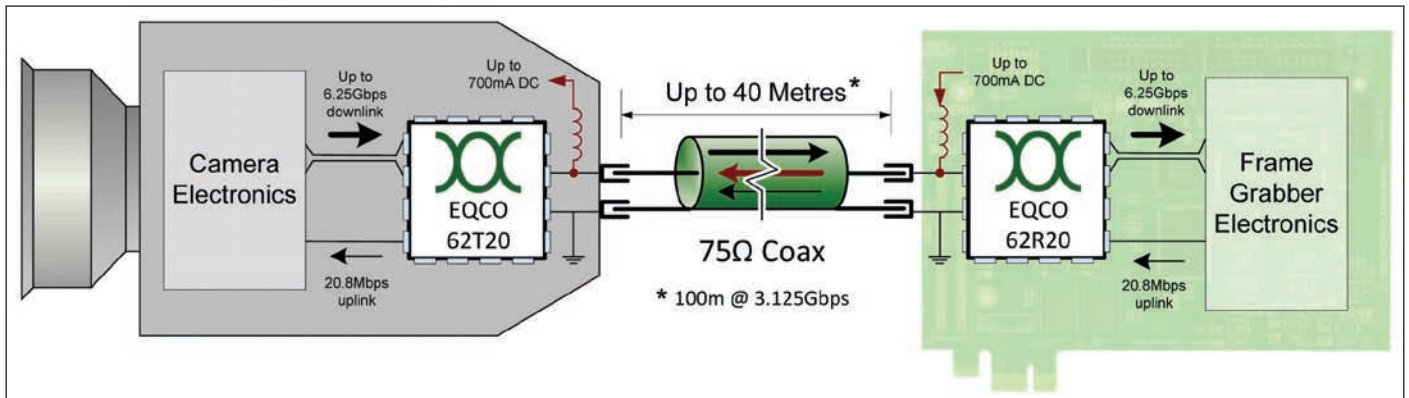

Block diagram of Camera and Frame Grabber (Courtesy EqcoLogic)

all expect high speed internet access over a simple twisted pair phone line – something inconceivable not so long ago. Similarly the recent revolution in HDTV uses HD-SDI (High Definition – Serial Digital Interface) in all studio and professional broadcast environments – and this runs over coax. The result is that due to this continually evolving serial technology and the chipsets that support high speed serial interfaces, it has now become possible to develop and propose a new standard, aptly named “CoaXPress” and able to transmit video data at 6.25 Gbits/sec along with power and control – all over a single coax cable. And be scaleable over multiple coax cables to provide huge bandwidths for systems of the future.

CoaXPress – the Background

The driving force for this new high speed technology derives primarily from im-



CoaXPress camera (Courtesy Adimec)

age sensor development and the resulting new applications that larger, faster sensors enable – this means much higher speeds are needed to acquire and process the data. Similarly, a low cost system solution using easy-to-use cost-effective coax cabling, supporting long cable runs combined with power and

control is also of great benefit. This will allow machine vision to penetrate into new markets as well as providing a great upgrade path for analog systems based around pre-installed coax cabling – especially in high-end medical and defence systems.

The core technology was developed in 2007/08 by Adimec and EqcoLogic, and a “digital coax” demonstrator was first shown at Vision 2008 in Stuttgart. In early 2009 Adimec recognized the need to bring in additional expertise from the frame grabber/system end and invited Active Silicon to join them. These three companies formed the “CoaXPress Consortium” with the goal of making CoaXPress a royalty-free world standard. Subsequently, further companies were invited to join the Consortium, at that stage carefully chosen to be non-competitive, thus resulting in a formidable close-knit working group containing leading technical experts from the industry.

The result was that by November 2009 when the technology was presented and demonstrated at the Vision trade show in Stuttgart, the CoaXPress Consortium won the Vision Award for innovation by unanimous vote from the international jury.

How Does It Work?

The physical layer, developed by EqcoLogic, is the key innovation of the standard-to-be: in order to transmit data at high rates some form of frequency based compensation, or “equalization” is needed to take account of the signal attenuation that increases with frequency and cable length. The received signal is filtered into many different frequency bands and each band is ana-

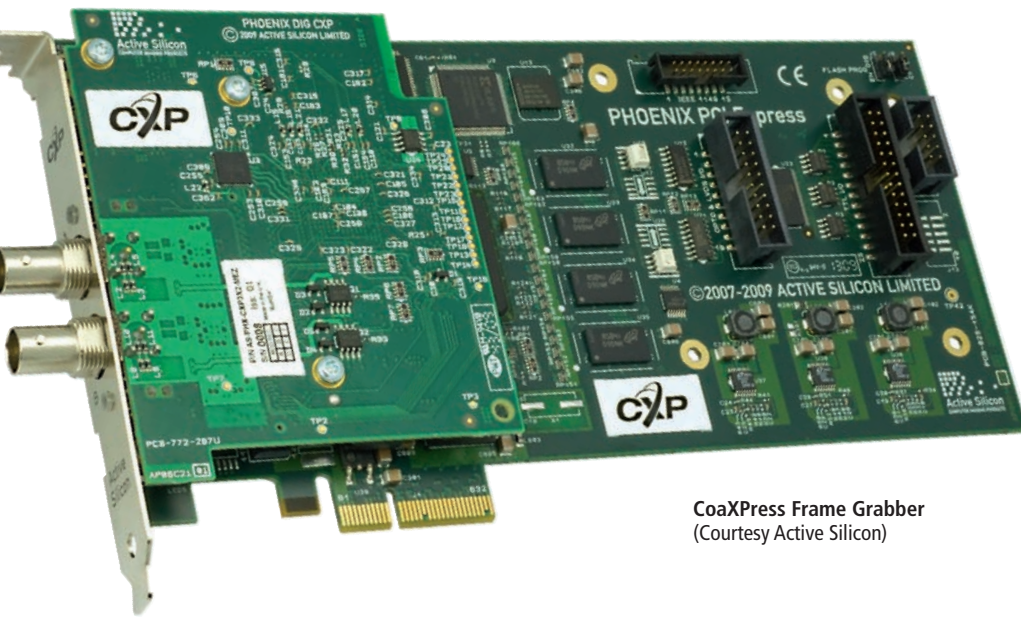

CoaXPress Frame Grabber (Courtesy Active Silicon)

Comparison Table

	CoaXPress	CameraLink	GigE Vision	USB 3.0
Single Lane Speed*	3.125 Gbps (Base) 6.25 Gbps (Full)	2 Gbps (Base) Single cable	1 Gbps	5 Gbps
Max Speed*	N x 6.25 Gbps (N x Coax Cables)	5.44 Gbps (Full) 6.8 Gbps (Deca)	1 Gbps	5 Gbps
Max Length	100 m / 40 m	10 m / 7 m	100 m	3 m
Cabling	Coax – and includes power at 13 W.	Custom multicore	Cat-5e / Cat-6	Multicore but low cost.
Data Integrity	CRC	None	CRC / Resend	CRC
Real-time trigger	Yes, +/- 4 ns	Yes	No	No
Complexity	Medium	Low	High	High

*Physical Layer Speed. CameraLink has no protocol overhead where as CoaXPress, GigE Vision and USB 3.0 all have some protocol overhead.

lyzed and adapted to compensate for the attenuation of the cable. The clever bit is that this is done dynamically in real-time to maintain excellent data integrity for the 6.25 Gbit/s “downlink” (camera to host). Then at the same time, a lower frequency “uplink” at 20 Mbits/s (host to camera) with careful edge rate control, so as not to interfere with the downlink, provides communication and control back to the camera. Since the data is AC coupled, it is a relatively easy task to also provide DC power to the camera. This is provided at 24V so as long cable runs can be accommodated, with a maximum of 13W per cable available at the camera.

In terms of the protocol, it follows the standard layered approach, with a logical top layer mapping to a stream which in turn is packetized for transmission at the physical layer. The protocol supports a variety of image and meta-data streams – for example conventional raw image data, compressed images, non-rectangular and multiple/dynamic regions of interest.

Why Coax?

The simply answer is that coax is physically the best, most reliable and consistent medium for the transmission of high speed data. Alternatives such as “twisted pair” suffers from intra-pair skew as speeds and distances increase. Coax also has many other useful benefits – low cost, simple to use, easy to terminate in the field, plus a large range of cabling, including multi-cores, are readily available driven primarily by the broadcast market (e.g. high flex, rugged environment, military grade etc). It should be noted however that fiber optic cable is also well

suited as a physical layer for CoaXPress. New initiatives such as Intel’s LightPeak, that can provide a physical 10Gbit/sec bi-directional link, given that it is protocol independent, looks like it could be a good fit for CoaXPress.

Standardization

For any technology to evolve into an international standard, a recognized hosting body is required and the CoaXPress Consortium has recently handed over ownership of the specification to the Japan Industrial Imaging Association (JIIA) for the standardization process that is anticipated to complete by the end of the year. In Japan, 60% of industrial vision applications still use analog cameras (and hence coax cable) so CoaXPress provides a good opportunity for the migration to high speed digital cameras with all the associated benefits of higher resolution and faster speeds. The EMVA (European Machine Vision Association) and the AIA (Automated Imaging Association) have recently voted (via the G3 Agreement between these hosting bodies) to support CoaXPress for the benefit of their members as a global standard. This support is subject to two conditions – firstly, that security of supply of the crucial EqcoLogic chips is guaranteed by placing the chip design into an escrow and secondly, that a reference design is made available by JIIA that provides an implementation of the transceiver interface using alternative off-the-shelf components as an alternative to the integrated EqcoLogic solution. For international standards, it is important that within reason, the implementation is not dependent on a single supplier component.

Further Information

Further information and technical details on CoaXPress may be found at www.coaxpress.com – this is a website that the CoaXPress Consortium is maintaining on behalf of JIIA as the focal point for technical information, news and general status about the standardization process.

► **Author**
Colin Pearce, Managing
Director, Active Silicon



► **Contact**
Active Silicon, Iver, United Kingdom
Tel.: +44 1753 650600
Fax: +44 1753 651661
colin.pearce@activesilicon.com
www.activesilicon.com

Adimec Advanced Image Systems, Eindhoven,
The Netherlands
Tel.: +31 40 23539 20
Fax: +31 40 23539 25
saleseu@adimec.com
www.adimec.com

EqcoLogic, Brussels, Belgium
Tel: +32 2 629 1301
phelfet@eqcologic.com
www.eqcologic.com

CoaXPress
info@coaxpress.com
www.coaxpress.com

The Right Choice

Key Questions for Camera Selection

The camera is a key element in machine vision systems that replace humans in industrial tasks such as inspection, metrology, and sorting. Many factors go into camera selection, however, leaving developers with a bewildering array of options to consider. Answering a few key questions about the specific application can help focus the search and speed selection, but they may not be the questions you expected.

Approaching camera selection by looking first at technology can quickly become overwhelming as many factors interact, forming tradeoffs that require careful consideration. Camera resolution, for instance, seems like a simple parameter with first reactions saying that the more pixels the camera provides the better. But pixel size can also be important. For a given pixel count, small pixels provide finer detail but a smaller image field, while large pixels offer wider exposure latitude.

Even pure pixel count has its tradeoffs. One that, in general, the more pixels a camera has the longer it takes to download the image for processing so frame rate (pictures per second) drops. In many industrial applications the camera frame rate can limit a system's production speed, hence manufacturing revenue, while highest resolution may not be required. As a result, camera vendors such as Imperx offer products with a wide va-

riety of pixel counts to allow optimum matching of speed and resolution to the application. The Imperx Bobcat series, for example, ranges from VGA (640 x 480) resolution at 250 frames/second to as large as 16 Megapixel at five frames/second.

CCD or CMOS

Other technology-based camera evaluation approaches can also quickly become confusing. Much has been made of the differences between CCD and CMOS imaging sensor technologies, for example, but what seem like benefits can quickly become liabilities with improper implementation. Because CMOS imaging uses the same base technology as digital logic, it offers an opportunity for creating compact designs through system-on-chip (SOC) integration. Yet the heat from the additional logic can also generate thermal noise in the image sensor, reducing image quality. And clever engineering using CCD sensors can achieve the kind of compact design that SOC integration promises without the thermal problems. The Imperx Bobcat cameras up to 5 Megapixel resolution, for instance, use 2/3-inch CCD sensors yet achieve a size of only 45 x 45 x 39 mm.

Application Requirements

Rather than approach camera selection by examining the various technology options, then, industrial system developers should explore the application in depth. One of the first questions to ask is 'What is the vision system looking at?' The answer to this question can go a long way toward determining the camera's resolution requirements as well as camera size and lens design. It also helps determine



Evaluating camera choices by examining base sensors such as this 16-Megapixel pixel Kodak KAI-16000 quickly leads to a tradeoff maze that can be simplified by first understanding key application requirements (Source: Eastman Kodak)

whether or not color imaging is required and if linescan-type cameras are feasible. Linescan cameras require either the object to be imaged or the camera to be moving at a steady rate in order to form a complete image, so lack of movement in the application can quickly narrow the field of choices.

Another key application area to explore is the operating environment. If the camera is to operate in an environment where vibration, moisture, or temperatures are excessive, a ruggedized camera may be required, further narrowing the field. The space available for the installation can also reduce choices. Developers should even understand object illumination characteristics such as wavelength, intensity, direction, and the like. A camera that works exceptionally well under controlled lighting conditions may perform poorly if dependent on natural illumination. Infrared or ultraviolet illumination may make key elements of an image more visible, but will require specialized cameras.

Once the camera acquires an image, what outcome or decision must arise? A simple pass/fail or sorting decision may only need a basic image that is within a simple camera's ability to provide. A metrology application that matches an image to a template may require a more sophisticated camera and the higher the metrology's precision needs the greater the resolution the camera must offer. Sophisticated quality control applications looking for subtle variations that can indicate the type and amount of process adjustments required often re-



When selecting cameras for industrial imaging applications, avoid technology-centric evaluation and consider implementation needs, instead (Source: Imperx)

quire high-performance cameras.

Processing Backbone

Another area to consider is the vision system platform with which the camera must work. Does the system have to be mobile or is it in a fixed location? Will it connect to a laptop PC or to a dedicated image processing host? Where is the frame grabber (image storage) for the image processor? Is the image processing to provide real-time decisions and metrology or is the image stored for later analysis?

With real-time image processing requirements, where is the processing to occur? In many cases a smart camera that provides some image pre-processing before delivery to the system can have major advantages. The Imperx Bobcat series, for instance, can perform tasks such as automatic exposure and gain control, white balancing, and other global enhancements in real-time to offload those tasks from the vision system and speed throughput.

Interfaces

The camera's connectivity is another important system issue to settle before making the camera selection. Camera-Link and Gigabit Ethernet are common camera interfaces and each has its strengths. Ethernet uses inexpensive cable and interface cards and allows the camera to be as far as 50 m from the image processor. It is bandwidth limited, however. While a Gbit/second sounds impressive it is relatively easy for a camera to exceed that data rate. A 2 Megapixel high-definition camera at 32 frames/second with at 12-bit dynamic range on the image already exceeds what the serial Gigabit Ethernet can sustain. Next-generation cameras will be offering 14-bit resolution.

CameraLink addresses the bandwidth issue by offering more than 200 Mbytes/second but requires a relatively expensive 24-pin cable and specialized interface. The cable is also limited to a 5 m run. On the other hand, CameraLink parallel structure provides a more robust and deterministic data transfer than the packet-based Ethernet, providing reliable real-time performance for activities such as triggering.

Finally, developers should consider the amount of in-house expertise they have available to apply to camera selection issues as well as software development for the image processing. With in-house limited resources developers should consider enlisting the help of camera vendors or distributors to help in the selection process. In either case, the answers to the key system questions will help guide the camera

selection process through the maze of possibilities.

► **Author**
Nathan Cohen, International
Sales Manager

► **Contact**
Imperx, Inc., Boca Raton, FL, USA
Tel.: +1 561 989 0006
Fax: +1 561 989 0045
sales@imperx.com
www.imperx.com



The Experience of more than 7,000
Applications World-wide.

NeuroCheck is the efficient solution for all application areas of image processing in manufacturing and quality control. More than 1,000 library functions, configured by mouse click in every conceivable combination, help you to rapidly create cost effective and reliable solutions for the entire field of industrial visual inspections. Your benefit: shorter realization time, company-wide standardization, and greater reliability compared to conventional programming. NeuroCheck represents a consistently integrated concept from the software through to the complete application including all vision components. **PLUG & WORK!**

For more information: www.neurocheck.com

NeuroCheck GmbH
Software Design & Training Center : 70174 Stuttgart / Germany : Phone +49 711 229 646-30
Engineering Center : 71686 Remseck / Germany : Phone +49 7146 8956-0
e-mail: info@neurocheck.com



Does GigE Vision Make Life Really Easier for the End User?

Optimal Customer Support through GenICam

With its 1,000 Mbit Gigabit Ethernet version – in short GigE – Ethernet has now become the third standard PC interface that is fast enough to transfer uncompressed images from the camera to the PC at sufficient speed. The advantages of GigE are obvious: More than twice the bandwidth of 1394a (FireWire) and USB 2.0, cost-effective components, and cable lengths up to 100 m.

But an interface alone does not make the image. To communicate with the hardware, the appropriate software, referred to as the protocol or transport layer, is required. The TCP protocol that is widely used in the IT industry is not suitable for image processing. Therefore custom protocols have to be developed for cameras. The Automated Imaging Association (AIA) initiated the definition of a standard that is currently marketed with broad public appeal under the GigE Vision trademark. Many camera manufacturers have applied this standard, thereby enabling their customers to use products from different manufacturers without problems, or so the ads say.

First and foremost, GigE Vision makes things easier for the camera manufacturers themselves, however, in that it simplifies and speeds up the product development process. Camera manufacturers now only need to develop the camera hardware. For the software, they license GigE Vision and distribute it with the camera. While many camera manufacturers have chosen this way and purchase GigE Vision for the protocol, others continue to develop their own software. The German machine vision specialist IDS Im-

aging Development Systems, for example, has launched a total of three GigE camera series based on their own uEye protocol. Thomas Schmidgall, Head of Marketing at IDS, explains: “The fact that everything – from camera hardware to transport layer – comes from a single source is important for customers the moment they run into any kind of problem. To be able to contact one person and right away get first-hand advice provides a solid basis for cooperation between the customer and the manufacturer.”

What about hardware interchangeability? For one, it is not so that with GigE Vision the application communicates directly with the camera. The application is actually integrated through the Generic Interface for Cameras – in short, GenICam – initiated by the European Machine Vision Association (EMVA). It is that generic (i.e. manufacturer-neutral) programming interface that makes the application independent of the hardware. But GenICam has much more to offer than just the features used by GigE Vision: The current version is designed for practically all types of image processing hardware. GenICam allows accessing a vast variety of devices, from the latest GigE

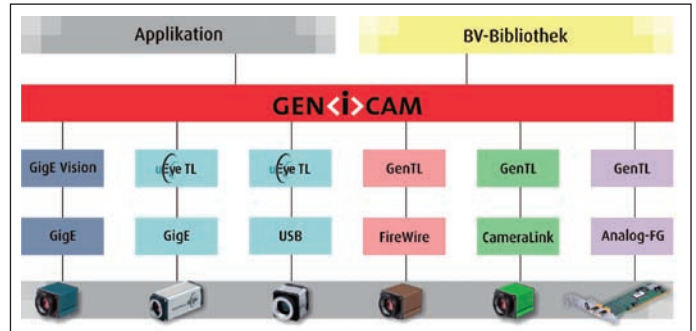

GenICam layer model

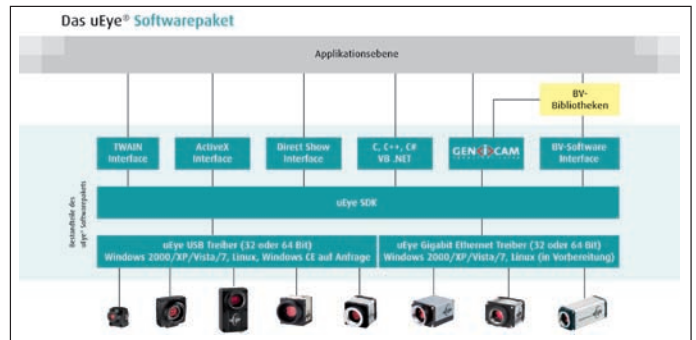

uEye SDK for all standard software interfaces

technology and smart cameras through to the widely used digital interfaces Camera Link, FireWire and USB 2.0.

IDS GmbH consequently offers GigE cameras with GenICam support, but has decided against the use of GigE Vision. “Based on our know-how from developing the USB cameras, we have developed our own GigE transport layer. This gives us technical possibilities we would not have had with GigE Vision. Just take our firmware philosophy, for example: A simple driver update at the PC automatically brings all connected cameras up to date. „That’s a huge advantage for customers, but requires dedicated camera drivers,“ Thomas Schmidgall points out.

When asking users to describe the ideal camera inter-

face, the most given answer would be “bandwidth, cable length, easy to use”. Now that GigE technology has taken hold in machine vision, the need for bandwidth and long cables should be satisfied well into the future. At the same time, thanks to the GenICam interface, the use of cameras in a multi-vendor environment has never been easier. Gigabit Ethernet has definitely only just started to conquer the world of machine vision.

► **Author**
Daniel Seiler
 Technical Communication

► **Contact**
 IDS Imaging Development
 Systems GmbH
 Obersulm, Germany
 Tel.: +49 7134 96196 0
 Fax: +49 7134 96196 99
 sales@ids-imaging.de
 www.ids-imaging.de

ifm electronic



Die dritte Dimension auf einen Blick.
Abstand, Füllstand oder Volumen optisch bewerten. Der neue 3D-Vision-Sensor.

efector[®]
pmd3d



Einzigartig:

Der erste industrielle 3D-Sensor, der auf einen Blick Objekte oder Szenen räumlich erfasst.

Die Auflösung von 64 x 48 Bildpunkten ergibt 3.072 Abstandswerte pro Messung für eine detaillierte Bewertung der Applikation.

Autark:

Beleuchtung, Lichtlaufzeitmessung und Auswertung befinden sich in einem industrietauglichen Gehäuse. Ebenso Schalt- und Analogausgänge für die einfache Integration in die Steuerungsumgebung.

Einsatzfreudig:

Ideal für unzählige Aufgaben in der Fördertechnik, Verpackungsindustrie und in Füllstandapplikationen. Leicht zu bedienen durch intuitiv verständliches Benutzer-Interface.

Besuchen Sie uns auf der
HannoverMesse 2010
▶ Halle 9 · Stand D36

www.ifm.com/de/pmd3d

ifm electronic – close to you!

ifm-Service-Telefon 0800 16 16 16 4

Panorama View

360 Degree View Ensures Efficient Part Inspection

In machine vision, many applications require a total view of all of the object's sides. Such inspections are performed using multiple cameras placed at strategic locations. But they increase the cost of vision systems. However, there are more economic possibilities to solve such tasks: intelligent high-tech lenses which ensure a 360 degree inspection.

Beer, wine or water – before filling liquids into bottles, it is necessary to inspect the bottles making sure they are free of slivers and contamination. The circumference of the container is checked for any defects in the neck. Also, the barcode has to be read out. In order to inspect the inner and outer surfaces of an object, a system of multiple cameras is normally used: Three or four cameras control the object from different angles of view. A further camera is required to also get the top view. With a computer and machine vision software, the images taken from all object surfaces have to be combined to form one single image. Although multiple camera systems work reliably, their usage goes along with high costs. Moreover, little available space often complicates the multiple cameras' integration. For these reasons, system devel-

opers often look to optics vendors to provide single-camera solutions that alleviate the need for image stitching or part and camera rotation.

Churn Out Outer Surfaces Inspection

When the outer surfaces of parts moving on a conveyor must be inspected, multiple camera systems often cannot be used since neighboring parts may obstruct the side views of the object to be inspected. By using pericentric lenses with a single camera, however, both a 360 degree image of the top and sides of the object can be captured. In such systems, an image of the lateral walls of the object is displayed around the image of the top surface of the part (fig. 1). The user gets one image that contains all information needed for the defect detection for this part.

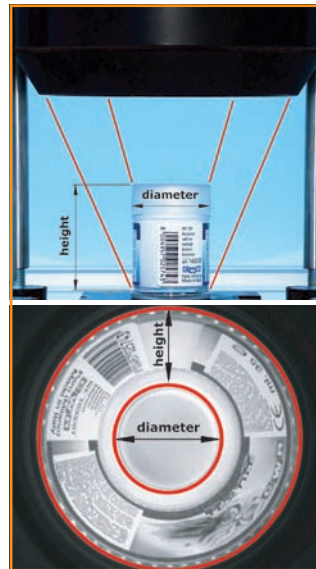

Fig. 1: A camera with a pericentric lens images both a 360 degree view of the top and sides of an object

Such pericentric lenses simplify system integration, since the parts to be inspected can pass freely in the space below the lens. Captured images are then unwrapped using software to obtain a linear view of the sides of the object and allow image analysis to be performed.

Inspecting the other surfaces of objects can also be accomplished by using multiple mirror systems. By this approach, an object is viewed through a mirror assembly using a telecentric lens. This allows four or more different side views of the object to be obtained (fig. 2). Because a telecentric lens is used, all the images are magnified equally allowing them to be correctly matched and measured using software. Even metrology tasks can be solved effectively this way.

Lenses for the Inspection of Inner and Outer Surface

One variation of this technique that provides multiple side views of the same object can be achieved using poly-view optics. These multi-mirror optical systems provide four, six, eight or more side views of the same object. This makes such systems suitable for inspecting the inner and outer surfaces of objects such as washers and grommets. Since the inner and outer side surfaces are displayed in the same image, all the relevant information needed to inspect such products is simultaneously displayed (fig. 3). PolyView optics provide a good image resolution and allow for high-speed image acquisition due to their short focal length.

PolyView optics can also be used for the inspection of cavities. In some cases, however, other optical solutions can be more efficient and compact. When bores need to be inspected, specialized optics can be used to generate images similar to those provided by pericentric lenses. Like pericentric lenses, these optics are designed to image curved surfaces. The wide perspective angle obtained provides a detailed view of these surfaces without the need to place an optical probe inside the part (fig. 4).

Special Applications

While such optics are useful, they cannot be used to image the interior of threaded objects. In such cases, it is nec-

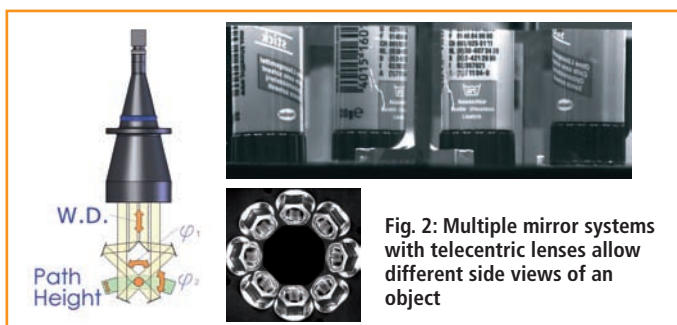

Fig. 2: Multiple mirror systems with telecentric lenses allow different side views of an object

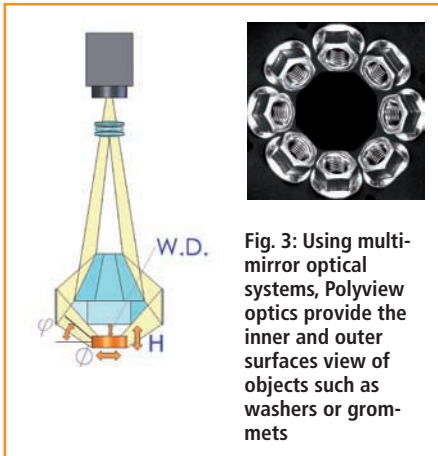

Fig. 3: Using multi-mirror optical systems, Polyview optics provide the inner and outer surfaces view of objects such as washers or grommets

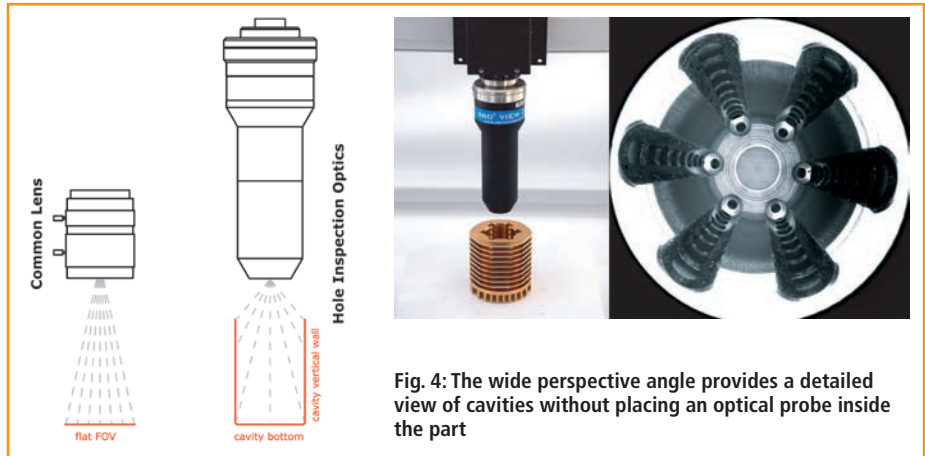

Fig. 4: The wide perspective angle provides a detailed view of cavities without placing an optical probe inside the part

essary to insert a fiberscope or bore-scope inside the part. Such products use bundles of coherent optical fibers to transfer images from the cavity to a camera. Unfortunately, the maximum number of fibers a bundle can contain limits the achievable resolution and when high-resolution images are required, a direct optical coupling with the camera must be used. This can be achieved by using optical probes that consist of a macro lens that images the cavity walls through a spherical or aspherical mirror. Such optical probes alleviate the need to scan the entire thickness of the cavity if the inspection can be limited to a specific cavity height.

When defects inside a cavity become very small, however, a much higher optical magnification is needed and a

smaller field of view is required. Since only parts of the interior surface can be inspected in a single image, the probe must both scan the height of the cavity and rotate to provide a full 360 degree view. Besides requiring an accurate positioning system for probe movement, this also requires specific software for image matching, since the image of the cavity will consist of numerous images obtained by scanning the interior surface and depth of the cavity.

Intelligent optics systems enable effective solutions for the complete image acquisition of a three-dimensional object. The necessary investment in cycle time, material and thus cost is significantly lower than that of a multi-camera system. In addition, the 360° high-tech op-

tics solution can be used when space restriction prohibits the integration of multi-camera systems.

► **Author**
Claudio Sedazzari,
 CEO Opto Engineering



► **Contact**
 MaxxVision GmbH, Stuttgart,
 Germany
 Tel.: +49 711 997996 3
 Fax: +49 711 997996 50
 info@maxxvision.com
 www.maxxvision.com

Opto Engineering, Mantova, Italy
 Tel.: +39 0376 263525
 Fax: +39 0376 2262432
 info@opto-engineering.com
 www.opto-engineering.com

Data + Power = Simplify

Full Spectrums of ADLINK Frame Grabbers Supporting "Power over Cable"

Power over Ethernet



Industry First

► **GIE62+**
2-CH PCI Express® PoE Frame Grabber

FireWire



► **FIW64**
4-CH PCI Express® IEEE 1394b Frame Grabber

Power over Camera Link



► **CPL64**
2-CH PCI Express® PoCL Frame Grabber

■ Simplified installation ■ Lower maintenance ■ Reduced total cost



Tel: +49-211-495-5552 | Fax: +49-211-495-5557
 E-mail: emea@adlinktech.com

www.adlinktech.eu

© 2010 ADLINK TECHNOLOGY INC. All rights reserved. All products and company names listed are trademarks or trade names of their respective companies.

Everlasting Marking – Reliable Identification

Reliable Decoding of Dot-marked Signs Even on Challenging Surfaces

Whoever can produce quicker, at higher quality and less expensively has the crucial competitive advantage. In order to maintain its position against global competition, the Danish company Sauer Danfoss continuously optimizes its processes. Therefore, the manufacturer of mobile hydraulics, electro-hydraulics and full-electric solutions has been looking for a labeling and identification system for its steering unit housings. The goal of the solution was to identify the parts reliably and safely in all production and logistics processes.

The unfinished part for the manufacture of steering unit housings consists of a macro-structured casting which changes its appearance profoundly throughout a range of processing stages using thermal deburring and chemical surface processes. This leads to extra requirements on the marking technology and the identification systems.

An additional challenge derives from the fact that the products continue to be manufactured in parallel on several lines, and precise positioning of the parts throughout the production process cannot always be guaranteed due to positional tolerances.

Suitable Marking Systems

Taking these conditions into account, only a form of marking technology which did not just apply the information to the surface but permanently marks it in the material came into consideration. This is the only way to guarantee that the infor-

mation is retained over the entire production process and continuing product life cycle. The decision was made for a dot marking unit made by Borries Markier-Systeme, Pliezhausen in Southern Germany.

The dot marking (dot peening) unit 322 with a PD20L dot matrix marking head was used. Borries marking systems are individually configurable in accordance with the defined customer requirements. The scribing and dot peening systems available from Borries have the benefit of higher flexibility in dot peened text, font height and widths in addition to marking depth. In the case of data matrix dot marking systems, there is an additional facility for applying an additional plain text. The low force required enables both solid, hollow and sensitive parts to be marked. The mechanical tolerance compensation also allows labeling of inclined and curved surfaces.

Borries Markier-Systeme produces machines and tools for direct, material-displacing and permanent marking. These systems can be found all over the world in the entire automotive industry and their suppliers, the aerospace industry, mechanical engineering, and the electrical and steel industries. Borries was founded in Ludwigsburg in 1952 and is today one of the most innovative and high-performance suppliers on the market. In addition, Borries Markier-Systeme has managed to retain the properties of a medium-sized company: transparency

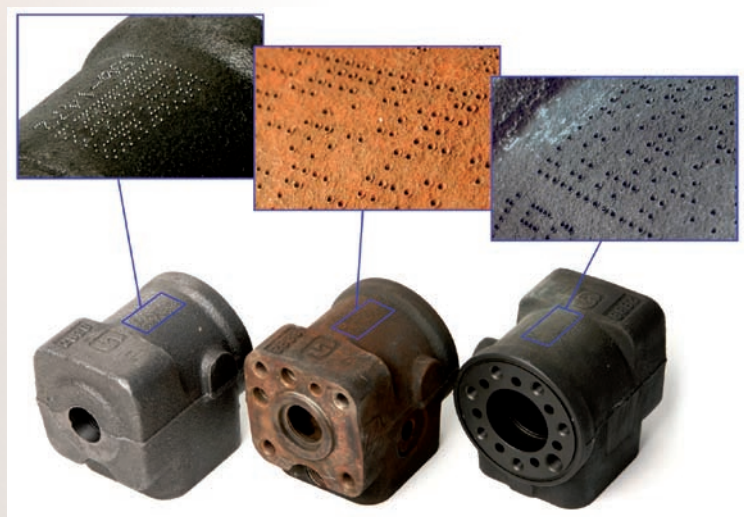

Steering unit housings in different processing stages



Borries 322 marking unit, which marks the code permanently

oily gloss surfaces). The modular design of the IOSS systems is one of the important issues when rapidly supplying a fool-proof system solution and integrating it ready for operation. The economic benefits for the client can be seen directly.

Optimum System Adaptation

In order to make the marked data matrix code visible to the reading algorithms, the first application technology solution approaches were initially tested experimentally. In this case, the focus was on visualization of the markings on the heavily structured material surface. In order to

meet the requirements on various forms of handling, the suitable illumination technology was selected from a wide variety of available modules and combined with the calculated lens system. This required a CAD-based implementation in cooperation with other integrators participating in the project. This service is provided by IOSS, who act as solution providers during

and reliability, short routes and safe processes in addition to the highest in quality requirements.

The data matrix code dot peened by the marking unit can be safely recognized even if the surface changes its properties considerably by using suitable reading technologies. One important aspect for successful implementation is the close cooperation between the suppliers of the marking technology and the reader systems. DMR210 data matrix reading systems made by IOSS were selected. The company headquartered in Radolfzell, Germany, has been operating in the ID industry for more than 10 years and has specialized in reading of directly-marked data matrix codings and in scribed OCR markings. The readers are successfully implemented in numerous sectors like Automotive and ancillary industries, electronic, solar, semiconductor and medical technology industries.

Modular Design

The DMR210 modular data matrix code reader system consists of a basic system and an additional wide range of application-specific illumination and lens units. Therefore the reader system could be rapidly adapted without any problems to all requirements of the varying product stages (unfinished part, thermal deburring of chemical coatings,



PUT YOUR INSPECTION ON COURSE TO WIN



► Common Vision Blox is the perfect software platform for quick and reliable vision application development. This fast, powerful, modular programming library supports all common acquisition technologies. Based on a set of highly optimized algorithms, users can even integrate custom code for total flexibility. For a cost-effective, truly industrial product, test Common Vision Blox today. *Imaging At Its Best.*

► VTX, Birmingham, UK, April 27-28, 2010, booth 1530

Download your own test version at:

► WWW.COMMONVISIONBLOX.COM

STEMMER[®]
IMAGING

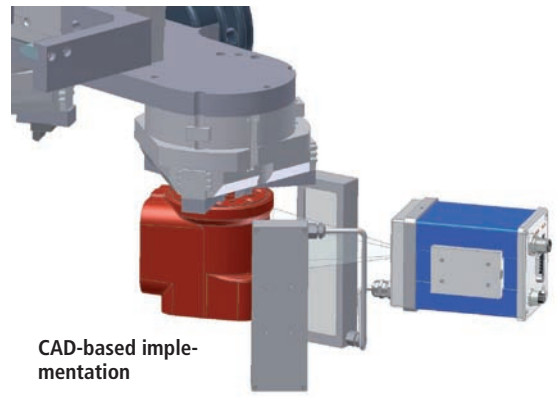
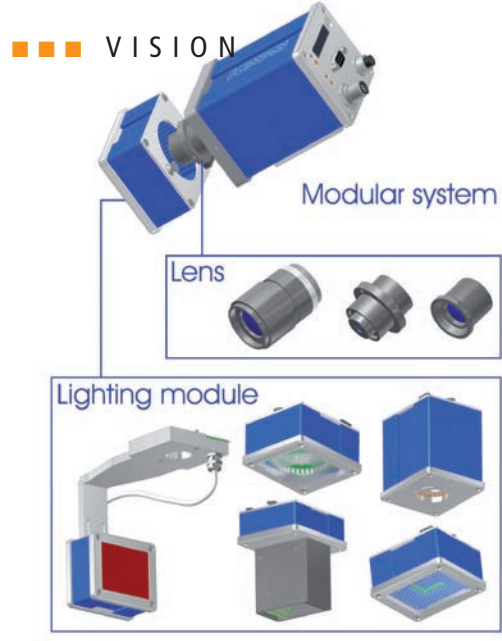

Stable Data Matrix Code identification in every process step ▼

▲ Modular Data Matrix code reader system DMR210

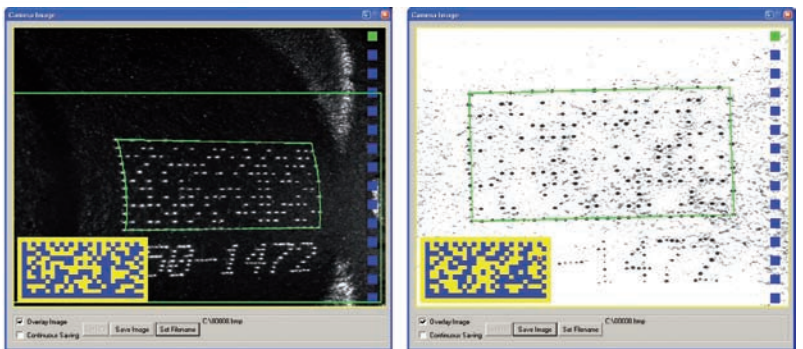

such projects, in order to offer the final customer a tailor-made solution.

Foolproof Reading of Geometrical Information

Practically-tested image processing algorithms developed by IOSS were used for the evaluation of data matrix markings made optically visible, which ensured rapid and stable extraction of the actual code information from the product surface, made difficult to read by the various processes. The fitting position causes a geometrically compressed image, which is also distorted due to the curved surface. This distortion is taken into account in the evaluation software in order to guarantee foolproof code evaluation. Thus the customer receives a precise and tailor-made technology from under one roof in which the system supplier can intervene at any point relating to the adaptation or changing of customer requirements.

On-site Integration Support

An important aspect for successful installation is the integration of the DMR210 reading sensor systems on site. Close cooperation between all participating equipment suppliers is a further important condition to achieve the required connections to the controller used for the factory data capture system. In the case of Sauer Danfoss, the IOSS sales technician gave an introduction on parameterization of the reading software for all project partners involved in the overall control system during instant training sessions. Extensive tests provided data material as a basis for optimization of the software settings.

The DMR210 can automatically save data during the production process in order to ensure further optimization of the system settings. This means that system parameterization can be rapidly and easily adapted during changing process conditions

without requiring on-site service.

By labeling its products, Sauer Danfoss has now the chance to optimize both, processes and procedures, through transparency and traceability. Key technologies are in that case the labeling and identification systems.



Optimized for customer series.

► **Contact**
 IOSS GmbH, Radolfzell, Germany
 Tel.: +49 7732 982 796 0
 Fax: +49 7732 982 79611
 info@ioss.de
 www.ioss.de

Borries Markier-Systeme GmbH,
 Pliezhausen, Germany
 Tel.: +49 7127 9797 0
 Fax: +49 7127 9797 97
 info@borries.com
 www.borries.com

Vision Sensors in Stainless Steel Housings

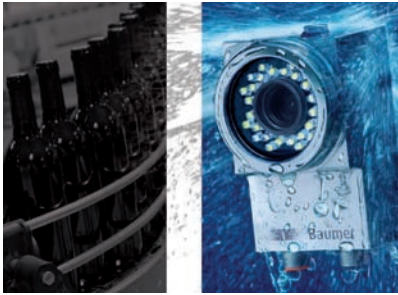

The new Baumer VeriSens Series 1500 and 1800 vision sensors feature stainless steel housings and IP69K protection class. They are developed for applications which demand high standards of cleanliness and hygienic control. Their powerful inspection, identification and character recognition capabilities can function

wherever required by the application – without additional mechanical protection aids. IP69K certified cables are available for integration. The Ethernet interface and Digital I/O permit easy system integration and configuration. The operator can easily achieve visualization and product changes via a standard web browser. In the food industry, for instance, the vision sensors can inspect packaged foods and read the best-before dates.

Baumer GmbH

Tel.: +41 52 7281122 · sales@baumer.com · www.baumer.com

USB 2.0 Cameras: Next Generation



The next generation of the USB 2.0 camera series mvBlueFox works more precise: A new analog-to-digital converter allows better conversion of the sensor data as well as an output of up to 1,024 gray scale values (10 bit). An image memory of 8 MB makes the camera flexible and robust in practice. The image data are buffered in the camera locally and can be sent again if transfer errors appear, in a tough

industrial environment with multiple cameras, for example. The range of available sensors for the second generation is extensive. CCD and CMOS sensor as gray scale or color version up to 5 megapixel are available. Especially for OEMs, Matrix Vision provides the industrial camera mvBlueFox as a manageable and flexible board level version.

Matrix Vision GmbH

Tel.: +49 7191 9432 0 · info@matrix-vision.de · www.matrix-vision.de

New Machine Vision Handbook

The 4th edition of Stemmer Imaging's popular Imaging & Machine Vision handbook is now available. The useful guide to machine vision is packed with over 50% more pages than issue 3. The comprehensive technology overviews featured in each section not only explain clearly how the products work, but also show how they can best be applied in machine vision systems. In addition to the updated technical overviews, the sections on cables and systems have been significantly expanded, while infrared cameras have been included for the first time. Copies of the new handbook can be ordered for free delivery in the UK, France, Germany and Switzerland by registering at Stemmer Imaging's Homepage.



Stemmer Imaging GmbH

Tel.: +49 89 80902 0 · info@stemmer-imaging.de · www.stemmer-imaging.de

New 3D Vision Software Tools

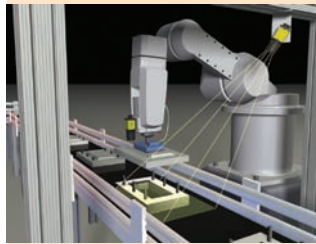

Cognex announces 3D-Locate, a library of 3D vision software tools that delivers accurate, real-time, three-dimensional position information. This enables automation equipment to work with a wider variety of parts, including items that are stacked or tilted. Cognex 3D-Locate uses multiple sets of two-dimensional features found by Cognex's patented geometric pattern matching tool, PatMax, to determine an object's precise three-dimensional orientation. PC-based the vision tool can handle high throughput applications, and users have the option to choose from a wide range of industrial cameras. Using 3D-Locate can improve vision performance for challenging applications such as logistics and robot-guided depalletizing and precision assembly. 3D-Locate is available as part of the Cognex CVL software library.

Cognex Germany, Inc.

Tel.: +49 721 6639 0

info@cognex.com

www.cognex.com

... for
everyone

GIGE[®]
VISION

**Zelos
Series**



Zelos-02150

Rugged 2/3"

High Definition CCD Camera

with GigE Vision, 14 Bit, 1920 x 1080 Pixel,
64 dB Dynamic, up to 30 Fps

Kappa opto-electronics GmbH

Germany | info@kappa.de | www.kappa.de

realize visions .

GigE Camera Series Includes Compact Models



The SVCam-Eco camera series from SVS-Vistek will be upgraded with two additional models: eco445 and eco618. These compact cameras (38 x 38 x 33 mm) complete the GigE Vision series and are available as monochrome and color version. The eco445 has a resolution of 1,280 x 960 pixels and delivers up to 20 fps, whereas the eco618 works with a resolution of 659 x 494 pixels and a frame rate of 100 fps. This model is IR-sensitive and

comes to operation where one works in a non-visible IR-area or where daylight influences need to be avoided. SVCam-Eco-cameras feature a 14-bit A/D converter and provide therefore a high image quality. They are used e.g. in quality control, for automatic optical inspections and for production monitoring but also for other general machine vision applications.

SVS-Vistek GmbH

Tel.: +49 8152 9985 5 · info@svs-vistek.de · www.svs-vistek.de

GigE Cameras at 60 Frames per Second



Basler expands its pilot GigE series with new models: The new monochrome and color pilot models capture 60 frames per second at full one megapixel resolution. The high frame rate is a key requirement for increasing the throughput in the factory automation market. In intelligent traffic applications and semiconductor and electronics manufacturing, the 60 fps rate is also a significant advantage. The pilot camera family is based on four selected Kodak CCD sensors and one Sony CCD sensor for high image quality and is equipped with a Gigabit Ethernet interface. For more flexibility, this series offers additional software features that can be integrated into the image processing software on a remote computer. The new models are already available.

comes to operation where one works in a non-visible IR-area or where daylight influences need to be avoided. SVCam-Eco-cameras feature a 14-bit A/D converter and provide therefore a high image quality. They are used e.g. in quality control, for automatic optical inspections and for production monitoring but also for other general machine vision applications.

Basler AG

Tel.: +49 4102 463 0 · info@baslerweb.com · www.baslerweb.com

Fast GigE Cameras Now Shipping



The Prosilica GX-Series presented by Allied Vision Technologies (AVT) is now available – with five sensors from 1 to 8 Megapixel. Running at 240 MB/s data rate, the GigE

Vision cameras work extremely fast. This new family of industrial cameras now includes 4 Megapixel (GX2300) and 8 Megapixel (GX3300) models. All models feature a specially designed thermal management enclosure to ensure optimal performance in the most demanding applications including machine vision, high-speed industrial inspection, license plate reading (ANPR), character recognition, robotics and surveillance. The Prosilica GX-Series cameras are equipped with the latest Kodak CCD sensors to offer good image quality, high sensitivity, electronic shutter, low noise, anti-blooming, improved smear performance and fast frame rates.

Allied Vision Technologies GmbH

Tel.: +49 36428 677 0 · info@alliedvisiontec.com · www.alliedvisiontec.com

Compact Smart Cameras

Vision Components offers compact smart cameras which are especially designed for applications with limited installation space. The board camera VCSBC4012 nano measures 40 x 65 mm, while the VC4012 nano camera line is built in size of 80 x 45 x 20 mm. This high degree of miniaturization was reached by populating both sides of the board with components. The intelligent cameras feature a CMOS sensor with a 5 Megapixel resolution. Therewith, they are optimally suited for use in high-speed applications. Furthermore, the smart cameras feature a 100 MBit Ethernet interface and an external trigger input which enables jitter-free image recording even at high reading frequencies. The Ethernet interface allows for video output on a PC. Two digital inputs and four outputs ensure integration into existing automation environments.

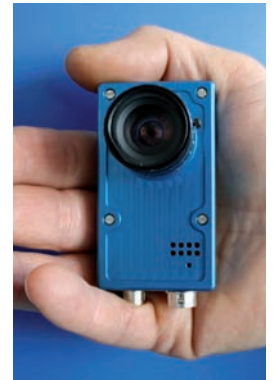

Vision Components GmbH · Tel.: +49 7243 2167 0

sales@vision-components.com · www.vision-components.de

Prozessanalyse leicht gemacht



Mit dem High-Speed-Vision-System PROMON SCOPE gewinnen Sie.

- Prozess-Optimierung
- Condition-Monitoring
- Störsachen-Lokalisierung
- Langzeitüberwachung

PROMON SCOPE – nachhaltig wirksam.

- einfachste Bedienung via Touch-Screen
 - bis 1200 Bilder/Sek.
- und mehrere Stunden Aufnahmezeit



www.aostechnologies.com

10 Megapixel USB Board-level Camera



IDS Imaging Development Systems announces a new 10 megapixel version of its uEye LE board-level cameras. Tailored to the needs of OEMs and system integrators, the smallest version of this USB camera line is only 7 mm high and provides a digital input, a digital output, two programmable GPIOs, and an I2C interface on a 36 x 36 mm chip. The UI-1490LE line is designed around the new 10.6 Megapixel CMOS color sensor with DigitalClarity technology from Aptina. The 1/2" sensor provides four times the resolution of HDTV at three frames/sec. In AOI and binning modes, the camera delivers frame rates up to several 100 frames/sec. The sensor offers low energy consumption and many built-in features, such as scaling and mirroring. A monochrome model is in development and scheduled for release in March.

IDS Imaging Development Systems GmbH
Tel.: +49 7134 96196 0 · info@ids-imaging.de
www.ids-imaging.de

Hardware Devices with Machine Vision Capabilities



National Instruments announced the addition of machine vision capabilities to NI CompactRIO and NI Single-Board RIO hardware devices that provide engineers with an integrated measurement and control platform for industrial and embedded systems. With this integrated platform solution, CompactRIO becomes one of the only programmable automation controllers (PACs) on the market to perform vision tasks, providing a more efficient, all-in-one design with a smaller physical footprint and less system complexity. It is an ideal solution for autonomous and semi-autonomous robotics applications for obstacle avoidance, pattern recognition and simultaneous localization and mapping (SLAM), where advanced control and vision functionality are required. Finally, the real-time OS and integrated field-programmable gate arrays (FPGAs) eases the process of FDA validation for embedded medical devices.

National Instruments Germany GmbH
Tel.: +49 89 7413130
info.germany@ni.com · www.ni.com/germany



Atom PC Camera in IP67 Housing

The Currera-R ruggedized Atom based PC camera from Softhard features 1.6 GHz Intel Atom processor, 1GB DDR and 4GB SSD, in a miniature IP67 protected housing. Computational real estate and extensive software

processing platforms allow to run common machine vision applications without adaptation, and even run respective development tools right on the camera.

With just two image sensor types and smart downsampling Currera-R covers all applications from VGA (100 fps) to 5 Megapixels with 15 fps, true global shutter, HDR imaging, color and B/W. Gigabit Ethernet with PoE, USB2.0, microSD slot, RS232, VGA and 8 isolated and fully programmable inputs/outputs facilitate integration into virtually any imaging system. Custom applications, Windows or Linux hosted, can be built on top of GenICam/GenTL or original Softhard SDK/API library.

Softhard Technology Ltd.
Tel.: +421 2 65459327
info@softhard.com · www.softhard.com

Ideal for 2D and 3D Metrology



The first available Flea3 models incorporate an 800 Mbit/s FireWire interface and are based on mono and color versions of the Sony ICX618 and ICX414. The Flea3 measures just 29 x 29 x 30 mm, and offers new features such as opto-isolated GPIO for industrial triggering and strobe output, non-volatile flash memory for user data storage, and on-camera frame buffer. The new CCD image sensors and even better imaging performance, makes the Flea3 ideal for applications in 2D and 3D metrology, electronics, semiconductor inspection, medical, and bioscience. The cameras are available to order now from Point Grey and its distributors. The first GigE Vision models are planned to be released to production and available to order by the end of second quarter 2010.

Point Grey Research · Tel.: +1 604 242 9937
info@ptgrey.com · www.ptgrey.com

3x extrem



SVCam-ECO Linie:
extrem klein

SVCam-CF Linie:
extrem schnell

SVCam-HR Linie:
extrem hochauflösend

Kameras von SVS-VISTEK haben schon eine Reihe von Maßstäben gesetzt. Erfahren Sie mehr über das breite Spektrum und unseren einzigartigen Service:
www.svs-vistek.de



SVS-VISTEK GmbH
82229 Seefeld/Deutschland
Tel. +49-(0) 81 52-99 85-0
info@svs-vistek.de
www.svs-vistek.de

Track, Trace and Control Solution

Microscan introduces its new Track, Trace and Control (TTC) solution, developed in partnership with Cogiscan. The solution features new Microscan TTC middleware, which ensures the efficient data collection combined with error proofing to demonstrate process compliance, while reducing material and assembly costs. The middleware provides complete, real time data visibility across the plant floor for any data collection points. This includes data collected from machine vision inspections, RFID, barcode and 2D readers. The TTC solution allows simple implementation, featuring Web-based controls and reporting, separate from the main IT plant floor network. Additionally, it features visual warnings and alarms if a product is scanned at the entry of the wrong operation or if the operation is out of sequence.

Microscan Systems, Inc.
Tel.: +1 425 226 5700 · info@microscan.com · www.microscan.com

New Series of Compact Smart Cameras



The new EyePC series by EVT are especially geared to applications of industrial inspection, machine vision and quality assurance. The system possesses a Gigabyte Ethernet Interface and optionally a Profibus, an Interbus or a CAN Bus Interface is available. The range of products includes mono-

chrome and color models with diverse frame rates and sensor technologies. The resolution of the sensors ranges from 640 x 480 to 2,048 x 1,536 pixels. The compact and powerful EyePC-cameras are equipped with an Intel 1.6 GHz Atom processor, 1 GB RAM and 16 GB Solid State Disk. Therewith the user has enough processing power to solve complex tasks. The smart cameras run under the operating systems XPe and Linux, whereas the user interface of the cameras is aligned with XPe.

EVT Eye Vision Technology GmbH
Tel.: +49 721 626 905 82 · sales@evt-web.com · www.evt-web.com

Higher Resolution in 3CCD Color Cameras



JAI announces the AT-140CL and the AT-200CL, the latest generation in its 3CCD color camera series. The new 3-by-1.4-megapixel and 3-by-2-megapixel cameras draw upon the company's expertise in prism-

block technology to provide a larger sensor format and higher resolution than previously available 3CCD RGB models. The AT-140CL features three 1/2-inch progressive scan CCDs (Sony ICX267AL), each with a resolution of 1,392 x 1,040 pixels and an individual pixel size of 4.65 by 4.65 microns. The AT-200CL uses three 1/1.8-inch progressive scan CCDs (Sony ICX274AL) to provide a resolution of 1,628 x 1,236 pixels with an individual pixel size of 4.4 microns square. The data's output occurs via digital Camera Link Interface. Currently, JAI develops versions with GigE Vision interfaces.

JAI A/S
Tel.: +45 4457 8888 · camerasales.emea@jai.com · www.jai.com

Shipping Sensors to Camera Manufacturers

IDS Imaging Development Systems has announced the introduction of a new camera which incorporates a NIT Magic CMOS sensor. In a move to differentiate its product

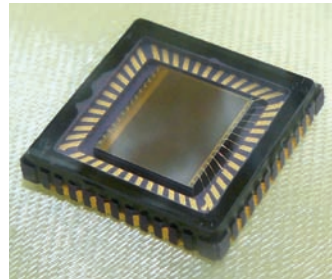

range and offer the best available technology, IDS has chosen to work closely with NIT, and has finally selected the MD1-10-B Logarithmic sensor for the design of its latest high-dynamic-range (HDR) uEye camera. This true logarithmic sensor developed by NIT uses an array of photodiodes operated in photovoltaic mode. The open-circuit voltage across the p/n junction is proportional to the exact

and pure logarithmic value of the incident light intensity. NIT aims to provide world class design of CMOS optical and imaging sensors to industrial, research, medical and defense organizations.

New Imaging Technologies (NIT) · Tel.: +33 1 60 76 46 48
info@new-imaging-technologies.com · www.new-imaging-technologies.com

Algorithm Prevents Pattern Formation

The camera manufacturer VRmagic has developed an algorithm that automatically corrects pattern formation in black-and-white sensors. These patterns occur if the same hardware is used for the black-and-white sensor as for a color sensor. In that case the signal still passes through three separate channels (red, green and blue) in the hardware. Using a black-and-white sensor, the channels lead to different gain values for neighboring pixels. It was necessary in the past to manually adjust the gain. The algorithm developed by VRmagic automatically measures and corrects these differences in pixel gain. The function has been integrated in the API and CamLab from VRmagic under the name "Auto Channel Balance" and is currently implemented for the camera models VRmC-9/BW, VRmC-9+/BW, VRmFC-9/BW and VRmDC-9/BW.

VRmagic GmbH
Tel.: +49 621 400416 0 · info@vrmagic.com · www.vrmagic.com

Machine Vision Software Runs on Mobile Phone

Test runs of the standard machine vision software Halcon Embedded have shown an outstanding performance on the mobile phone Nokia N900. The tests have proven that applications based on Halcon can successfully be built for the Nokia N900. First, the application can be developed on a PC. After this, the exported code is compiled for the Nokia N900 to run the application on this mobile platform. Thus, all image processing applications are possible which are interesting for mobile platforms as there are character recognition (OCR), reading of documents, bar code and data code reading, pattern matching, and the counting of objects. The benefit of a mobile phone: By the integrated camera, data can be acquired at any place which can be transmitted worldwide fast.



MVTec Software GmbH
Tel.: +49 89 457695 0 · info@mvtec.com · www.mvtec.com

Ensuring Competitiveness through Machine Vision

Leading Edge 3D Bin Picking Solution for the Casting Industry

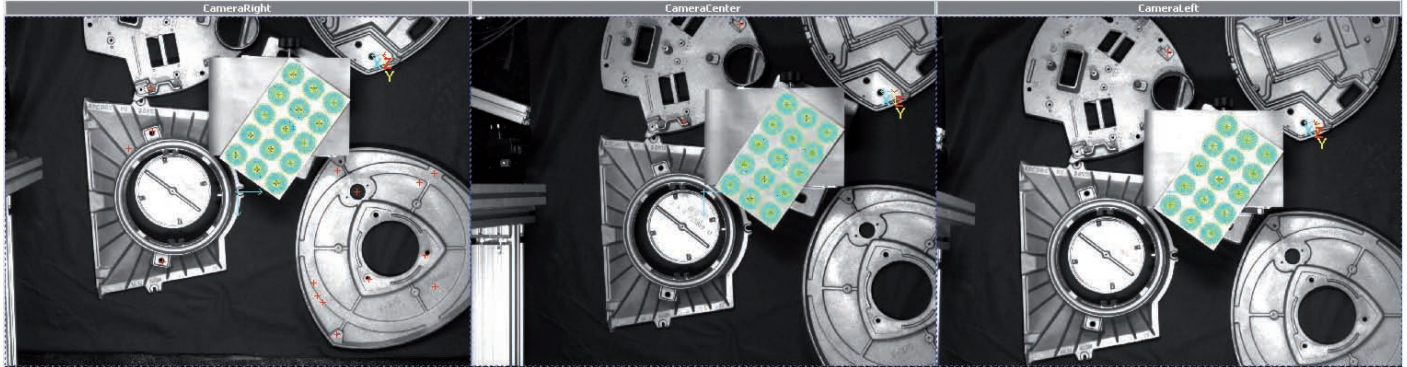

The leading Norwegian manufactures of castings need new technology to meet the international competition and the environment-, health- and safety requirements. This results in strong emphasis on developments with the potential to enhance the use of automation and robotics in the foundries. The small series production does not allow for unique solutions for individual parts. The main challenge is therefore to develop generic solutions that can be used for different parts or families of parts.

Considerable focus on R&D in the past has put the Norwegian foundry industry in a leading position regarding casting and materials technology. However, high salary costs and lack of labor-power has created a need to make further use of automation and robotics. To address this, the Norwegian foundry industry has pooled their resources in the R&D project

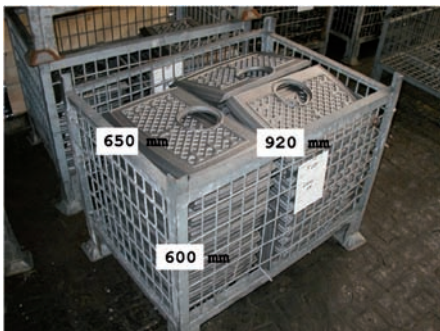

Fig. 1: Typical Bin for AutoCast Bin Picking

“AutoCast” with the goal to develop state of the art technology that will ensure their competitiveness.

AutoCast, supported by the Norwegian Research Council, started in 2008 and is planned to run for four years. The total budget is € 5 million.

AutoCast 3D Machine Vision Goals

The project is set out to develop a machine vision platform consisting of concepts, methods, software, 3D camera technology, and lighting principles, set out to obtain and use measurements of three-dimensional geometry. The technology is to be applied to the automatic picking of 3D objects with a robot, the product control and management of production. The technology will be cost effective and aims at having a low user threshold. The platform shall be used to identify, pick and trace casted parts. The system must be able to be reconfigured for a new part in less than 15 minutes. The latter requirement takes into account that there is a large number of over 1,000 casted parts in a typical casting factory.

Tordivel Chosen for AutoCast

Tordivel AS, the company behind the Scorpion Vision Software, has been chosen as the 3D Machine Vision Partner for the AutoCast project. Tordivel was founded in 1992 and has developed machine vision solutions since 1996. Since 2000 the Scorpion Vision Software is offered as a product. In 2005 Tordivel decided to move Scorpion from a robust and proven 2D version to a complete 3D platform. The

development has been supported by several R&D projects. The EU-CRAFT consortium 3DMulticam has developed a platform for 3D underwater metrology while the Auto3D project has the focus on creating a low cost complete framework for 3D Machine Vision including stereo vision, stripe light, 3D visualization, 3D references, applying 3D to 2D images and true 3D processing of point clouds.

Scorpion Vision Software is an open and independent software solution for industrial vision systems. An important success factor for the Scorpion Vision Software is the extensive use of visualization and the introduction of methods and concepts that make complicated mathematics available for non-specialist users. Scorpion Vision Software 8.0 was launched in January 2010 and contains all the results from the 3D research conducted since 2006.

AutoCast R&D Challenge

The major technical challenges of the AutoCast project are to create a system that is sufficiently flexible and that can easily be reconfigured and used for a new measurement problem, to develop algorithms for robust detection and basic training in a set of known 3D objects



Fig. 2: Casting part full of features

Fig. 3: Selected marker shape featuring a circle and an interior direction



stacked in a bin, and to transfer knowledge to the casting companies so that in the end they can develop, deploy, and maintain their own 3D systems. The final solution has to master both scenarios: the identification and location of parts on a conveyor, and the segmentation and 6DOF location of parts in a bin.

In this article we will focus on 3D Bin Picking as shown in figure 1.

Stereo-Vision with Three Cameras

It was obvious that a 3D machine vision solution was needed to solve the 3D bin picking task. After evaluating stripe light, 3D laser scanners and stereo vision, a solution based on three GigE cameras and 3D stereo vision was selected.

There are several reasons why this solution was given preference:

- fast – a part is located in less than one second, thus the method works even when objects are moving on a conveyor,
- robust and reliable – since all three camera must agree to accept the estimated 3D location,
- accurate – within a volume of 650 x 600 x 900 mm a part is located with a resolution of 1 mm,
- economic – low component cost.

Markers to Eliminate Training

The traditional challenge in stereo vision is to find features that can be used to locate a part. The typical casting part is normally full of features and thus easy to locate (see fig. 2). The drawback of using features, however, is that subse-

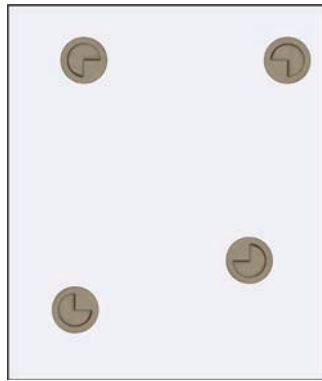

Fig. 4: All four markers point to the center of the part

quently a location algorithm needs to be trained and tested for every single part type. This is a time consuming and costly process and limits the ease of use.

It has therefore been decided to actively add the features already in the casting process in the form of four casted markers per part. An example of the selected marker shape, which consists of a circle and an interior direction, is shown in figure 3. This design allows the marker to be located with sub pixel accuracy in a non uniform illumination scenario. The marker concept will also make it possible to locate parts without any features present.

Segmentation of Parts in a Bin

The markers can be used to segment the parts in the bin.

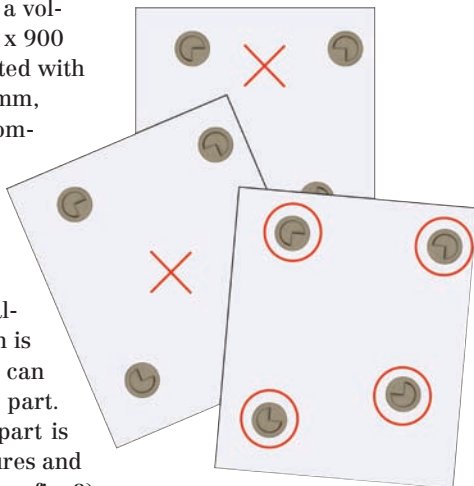

Fig. 5: The topmost part can be picked

There are four markers positioned on each part all pointing to the center of the part, see figure 4.

Figure 5 shows how three parts can be segmented in 2D. The part at the bottom is eliminated by using the marker direction only. Using the marker height or z-coordinate will increase the ability to segment.

The process of adding new part types to the system is greatly reduced to a simple operation of adding the 3D coordinates for four markers compared to the complex task of teaching features. This will be done by the system operator and completely removes the need for machine vision competence in the daily operation of the system.

Innovative Concept for Marker Location

For the localization and segmentation of multiple parts in a bin, a new tool has been developed that locates multiple markers: the CircleSegmentor. With traditional pattern matching algorithms it proved to be impossible to achieve the required combination of robustness and accuracy.

The CircleSegmentor is able to locate multiple markers or overlapping circles with sub-pixel accuracy making use of the Scorpion Vision PolygonMatch technology. The tool that has been released with Scorpion Vision Software 8, allows for a linear speed up on multi-core processors, and is fast and reliable using an advanced four steps marker validation:

- intensity independent algorithms locate all edges.
- a random search algorithm locates marker candidates based on the edge and size or radius of the marker.
- PolygonMatch locates the outer circle of the marker with sub-pixel accuracy even if the marker is partly occluded.

- a second PolygonMatch step identifies the direction of the marker.

These four steps ensure the best robustness and the highest accuracy in marker location.

3D Bin Picking

The first step to locate a part in the bin is to locate all markers in the three images in 2D, next all markers are located in 3D using three camera stereo vision combining the 2D position with a 3D calibrated camera. Then all markers are removed which are not located consistently, and finally the topmost part is selected and three out of four markers are used to create the configured 3D picking points for this part.

Important system properties are that a part is reliably located with only three markers present and an error free object location is guaranteed by three camera stereo-vision.

Conclusion

We have presented a 3D machine vision technology developed in the Norwegian Auto-Cast R&D project that will keep the Norwegian foundry industry in a leading position. The 3D machine vision solution is based on the off-the-shelf Scorpion Vision Software from Tordivel. This concept for accurate, low-cost 3D bin picking is ready to be used in a vast number of industries.



► **Author**
Thor Vollset,
Managing Director Tordivel

► **Contact**
Tordivel AS, Oslo, Norway
Tel.: +47 2315 8700
Fax: +47 2315 8701
office@tordivel.no
www.tordivel.no

Surface Inspection in Real-time

Inspection Solutions for Online Quality Control of Castings

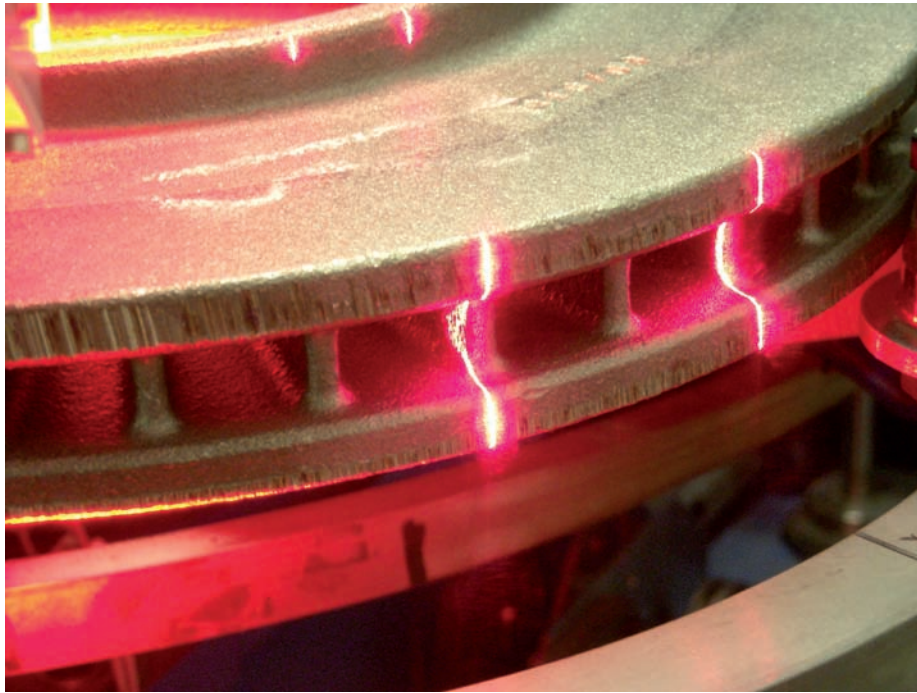

Before further processing, the quality of castings' surfaces has to be controlled. For this task, the measurement methods which are available on the market are either too slow for online use or not sufficiently flexible for frequent product changes, says Edixia, the provider of inspection systems. Thus, the company offers a technology which scans all surfaces of a product during the production run and analyses the 3D images thanks to an image analysis program. This way surface inspections as well as geometry measurements can be performed in real-time; results are available immediately in order to take corrective actions upstream. The machine vision solution is also suited for the continuous optimization of manufacturing processes.

Edixia offers its frame grabbing and image processing technology within the product range 3dCast. It is based on the principle of laser triangulation and consists of a laser beam projector, a system of sensors, patented optics for avoiding shadow effects and an optical filter to eliminate reflections. The system's measurement resolution is determined by three coordinates: camera axis, movement axis and triangulation axis.

Overall Profile of Multiple Scans

Since it is usually necessary to check more than one side of a foundry product, 3D-Cast technology enables several sensors to be used at the same time for different sides. In this case, sensors are calibrated relative to each other within the machine so that they all work within the same system of coordinates. With this type of arrangement, all scanned contour lines can be combined into a single overall profile. This is achieved by creating a scatter of points in which each point represents the component's visible X, Y and Z coordinates, with a maximum resolution of 10 µm.

In addition, the application provides various log files. All results are saved in a statistical database. Implemented statistical checks are then carried out, including six sigma, control point histograms and trend analysis.

► **Author**
Thomas Simon

► **Contact**
Edixia SAS, Vern sur Seiche, France
Tel.: +33 2 99628611 · Fax: +33 2 99627238
customer@edixia.com · www.edixia.com

Mini size
maX
performance

mvBlueCOUGAR-X

Next generation GigE cameras

- X**-quisite quality CCD & CMOS sensors up to 5 MPixels
- X**-tra flexible onboard hardware preprocessing
- X**-tra micro-PLC for sequencing
- X**-treme smart I/O: protected high current outputs
- X**-tra fine resolution ADC (14 bit)
- X**-large camera memory (96 MByte)
- X**³-performance: image, integrity, insurance
- X**-tra compact and rock solid housing with locking connectors
- X**-tra board level version available
- X**-tendable by feature options
- X**-cellent value for money

mv **MATRIX**
VISION

MATRIX VISION GmbH
Talstrasse 16 · DE-71570 Oppenweiler
Phone: +49-7191-94 32-0
Fax: +49-7191-94 32-288
info@matrix-vision.de
www.matrix-vision.de



Painless Puncture

Optical Quality Control of Infusion Sets

Because of their fear of the puncture, many patients are afraid of syringes. This can be avoided through flawless products which enable almost painless punctures. That is the reason why the medical technology manufacturer BBraun Melsungen proves its infusion sets with machine vision systems by Vitronic with respect to correct assembly and flawless function.

30% of Germans who are afraid of the dentist pass on medical care because of their fear of the anesthesia syringe. So, the goal of the scientists at the University of Mexico was that the children's fear does not come into existence in the first place. That is why they decorated the sy-

ringes with motives of butterflies and smiley faces. According to the study, the number of fearful children dropped from 63% to 10%. The manufacturer of the infusion sets, BBraun Melsungen, knows as well about this antipathy to syringes and the fact that blunt needles are painful and may injure the patient. In order to guarantee the flawless functioning of the infusion sets, BBraun relies on Vitronic's machine vision systems in its factory in Malaysia. There, the machine vision system checks product characteristics with respect to compliance with specifications at several stations. This includes the correct attachment of the plastic cannula, the polished section and the point of the steel cannula, as well as the installation and the correct positioning of the so-called "Safety-Clip". The latter was developed to provide the highest protection from accidental puncture wounds to the medical personnel. BBraun uses the Safety-Clip in the product lines Vasofix Safety and Introcan Safety.

Safety at Each Puncture

An infusion set consists of a steel needle and a surrounding plastic cannula. The vein is punctured with the steel needle and the plastic cannula is simultaneously introduced into the vein. The steel needle can be removed once the cannula has been successfully positioned. The safety mechanism is automatically activated when the needle is pulled out of the plastic cannula. A metal clip, the Safety-Clip, snaps over the needle point and prevents puncture wounds and infections. This way, the further use of the cannula becomes impossible. The safety mechanism can neither be circumvented nor unintentionally activated or deactivated.

Plastic Cannulas on the Test Stand

In the production process, the plastic cannulas are cut to the corresponding lengths and connected to the capillary housing. Afterwards, the cannula tips undergo a special attaching process. Now, the machine vision system Vinspec is coming into operation. The plastic cannulas to be inspected are transported to the machine vision system in a workpiece carrier. Six plastic parts are respectively inspected simultaneously from all sides. This allows an all-around qualitative evaluation of the cannula. The plastic cannula undergoes an attachment process patented by BBraun. Only this special attachment makes it possible to insert it into the vein, namely in an almost painless fashion. Vinspec checks the cannula points with respect to the presence



Vinspec checks the needle point in the μm -range



The completed infusion sets are checked with respect to 100% quality and completeness

of and deviations from the special shape. Other specific characteristics are also checked. This ensures that only flawless products leave the production facility. The simple and almost painless insertion of the infusion sets in each individual instance is only made possible by the utilization of industrial machine vision.

Tested Protection

The infusion sets are checked with respect to 100% quality and completeness at various test stations. The most important characteristic of the production lines Vasofix Safety and Introcan Safety is the Safety-Clip. In order to ensure that it fulfills 100% of its protective function, Vinspec checks if the metal clip was placed into the capillary housing and correctly positioned. If the metal clip shows deformations or is seated in the capillary housing in a twisted fashion, Vinspec sends a "defect" signal to the master system control. Thereupon, the part is sorted out.

Needle Point in μm -Range

The machine vision system Vinspec checks the needle point in the μm -range. A blunt needle is painful and may even injure the patient. However, the polished section of the needle needs to be correct and checked. If the needle point and the polished section are optimally adapted to one another, a vein can be punctured in a highly precise and practically painless fashion. Vinspec compares the con-

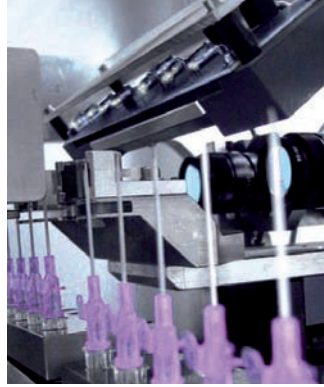

Safety according to GAMP with the machine vision system Vinspec

tour of the infusion sets in order to obtain information on deviations and the completeness of the cannulas. The comparison is realized with a previously scanned-in sample. In this context, the length ratios of the plastic cannula referred to the needle are particularly important. Significant deviations may lead to subsequent complications for the patient. If the plastic cannula has an excessive length and covers parts of the needle point, a vein can no longer be punctured. The machine vision system Vinspec eliminates all these scenarios. If tolerances are not met or defective cannulas are detected, a signal is immediately forwarded and the part is sorted out. After the infusion sets have successfully undergone all optical checks, they are immersed in a silicone bath, the needle is provided with a protective cap and the cannulas are placed in sterile packaging.

At a Glance – Live Images

A computer system with a monitor is connected to each test station. The operator can view live images of the individual checks and the most recent test results. The software precisely shows the operator the position of a tolerance deviation. Production drifts are therefore detected in a timely fashion. A fast intervention in the production process makes it possible to avoid costly consequential defects. All test results and defect images are stored and can be statistically evaluated.

Optical Quality Check for a Range of Cannula Types

BBraun produces various types of infusion sets in different sizes. Vinspec can be quickly adjusted to the new type. Due to the Quick Tech function, a sample part merely needs to be transported through the system once and Vinspec can check the new type without time-consuming alterations. The tolerance limits can be changed just as quickly and easily. Tolerances can be reset with a few clicks. The system is automatically calibrated during each test cycle due to permanently installed online calibration templates.

Safety According to GAMP

All Vitronic image processing systems can be validated in compliance with the GAMP

qualification packet: the basis for quality control in the manufacture of products in the medical and pharmaceutical industry. All relevant events such as users logging in and logging out, tolerance changes and accessing the defect images are stored in a tamper-proof protocol data file.

► **Author**
Martin Schumacher,
Manager Medical Technology

► **Contact**
Vitronic Dr.-Ing. Stein
Bildverarbeitungssysteme GmbH
Wiesbaden, Germany
Tel.: +49 611 7152 0
Fax: +49 611 7152 133
sales@vitronic.de
www.vitronic.de



Expeditious and elegant, evolving visions

3D MACHINE VISION

Scorpion Vision Software® is a complete 3D image processing framework including 3D reference systems and 3D visualisation.

Scorpion Vision Software's ability to combine 3D reference systems with any 2D image is unbeatable!

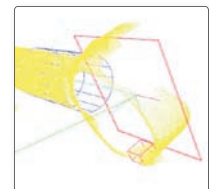

Tordivel AS
Storgata 20, N-0184 Oslo, Norway
Phone +47 2315 8700 • Fax +47 2315 8701
www.scorpionvision.com • office@tordivel.com

German Partner:
Polytec GmbH www.polytec.de • info@polytec.de

Scorpion Vision Software® is a registered trademark of Tordivel AS.



Polytec

Fresh from the Oven

Inspection of Technical Ceramics in Furnace Processes

Flickr, Martin Calhage

Today, anyone who switches on a kitchen oven benefits from the modern components made of technical ceramics. The material withstands extreme temperature fluctuations, exhibits high strength and is resistant to wear. However, hair cracks, contamination and air entrapment repeatedly occur during production, considerably depreciating quality. Automated optical quality inspection is therefore essential.

When, in the 19th century, the large-scale construction of electricity supply grids began, the engineers discovered the positive characteristics of porcelain as a corrosion-proof insulator. Technical ceramics were born. Strength, resistance to temperature fluctuations, surface quality and differing electrical properties make ceramics versatile in application. The production process makes this material

something special. In contrast to metals, for example, the material characteristics are not predetermined from the outset, but originate exclusively through the method of production. The achievement of the manufacturer lies in the ability to control this process, so that the respective desired material characteristics are generated. Just as the shape and characteristics of a porcelain plate are virtually unchangeable following the firing process, the same also applies to technical ceramic components.

100% Reliability at 900 Parts per Hour

Ceramic components can be shaped by means of pressing or by injection molding. Axially symmetrical components such as axles or tubes can also be produced by extrusion, similar in principle to the potter's wheel. However, quality inspection is required at the end of the process. The surface quality of the work pieces must be inspected in accordance with the subsequent loading. For example, a component intended for use as the combustion chamber in an engine must be scanned for fine hair cracks. Contamination or the entrapment of minute quantities of air in the material can also significantly impair the quality. Therefore, automated inspection processes based on image processing are required. In this, the engineering firm ICW Christian Wölz in Augsburg, Germany, is specialized. The company works as system integrator for Omron and has recently constructed a complete inspection sys-

tem for a customer from the ceramics sector which, even at the high throughput capacities of up to 900 components per hour, guarantees 100% reliability in the detection of defects.

The heart of the inspection system is the Xpectia machine vision system from Omron. At present, it can process the signals from up to four five-megapixel cameras and is suitable for both two- as well as three-dimensional inspection of components. Like the human eye, this system can detect all types of objects, of any size and color combination (16 million colors), from any distance. The camera images can be evaluated in real time, according to the specified parameters. These parameters are freely configurable on an IPC platform. In this way, individual inspection sequences and decision-tree structures can be defined, which ultimately result in each work piece receiving an overall assessment as good or defective, in accordance with these quality characteristics. ICW not only took charge of the system adaptation on the information-technology level, but has also designed the mechanics of the entire inspection system, so that quality inspection is integrated directly into the ceramic production process.

Quality Inspection in Multiple Stages

Firstly, the machine for ceramic production is configured in accordance with the formula, in which the characteristics of the relevant material type are precisely described. Thus, any number of work pieces from a particular batch can be inspected. The automatic process then begins. The system is loaded by means of a changeable magazine. The work pieces may be of differing diameter and material thickness. There are three different magazine sizes for diameters of 18 mm, 32 mm and 38 mm. Material thickness can vary from 0.1 mm to 6.35 mm. The mechanics of the device are infinitely adjustable and can therefore be ideally configured for a wide range of ceramic thicknesses.

Inspection Point by Point

The inspection system consists of three camera fields of view. The first camera serves the position determination. With this camera, the system detects the geometry of the work piece, i.e. the product-dependent surface characteristics such as holes, grooves and recesses. In this way, the optimal rotational position for the actual quality inspection is deter-

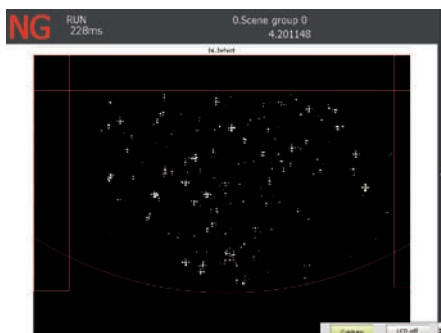

Depiction of detected surface defects

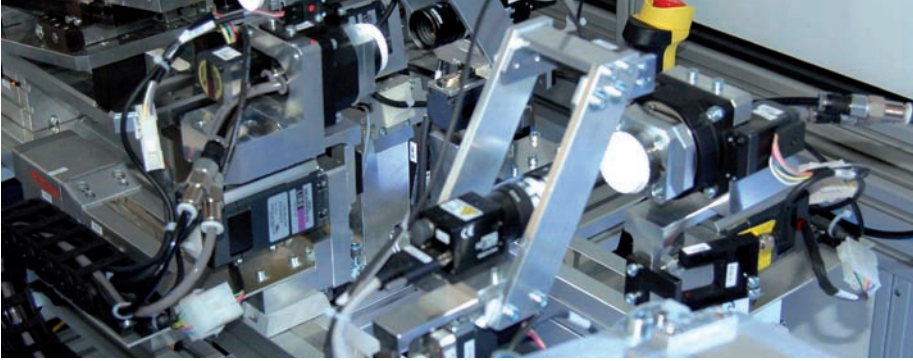

The inspection system consists of three camera stations



The defect detection is performed with an accuracy down to 10 µm

mined, which is sequentially performed by the other two cameras. This first step is decisive, as it is essential that all inspected pieces are assessed in the same initial position. The machine vision system determines the alignment with absolute accuracy. The further transport of the work piece is by means of ceramic-covered rotational suction devices in order to prevent possible contamination through the system itself.

The quality inspection then takes place with the second camera – firstly on the front side. For this purpose, the camera scans the material structure as finely as possible. This produces four high-resolution images which, together, depict the entire front surface of the ceramic component. The freely rotating suction elements move the work piece to any desired position. Precise regulation of the vacuum ensures that the components are not damaged.

The inspection itself is on the basis of homogeneity, as the system does not work using a model, but examines the surface structure of each individual work piece. The surface is compared point for point with reference to itself and is examined for defects. The image processing system is so accurate that it can detect defects down to a value of 10 µm, or even smaller tolerances. In accordance with the specified parameters, the Omron vision system identifies all irregularities in the surface, including for example pores, hair cracks, contamination, discoloration and bumps.

The work piece is reliably transported to the third camera, where the same procedure is performed once again, this time for the back of the component. After com-

pletion of the entire procedure, the inspected components are deposited in magazines sorted into “good” and “defective” products. Laser distance sensors continuously monitor the levels in the magazines. The entire system is of a flexible design and can, within a few minutes, be converted for quality inspection of ceramic components with a completely different shape.

Core Components from One Source

The system designed by ICW is a sophisticated complete solution, consisting of 70% Omron components, thus uniting all customer-relevant quality assurance characteristics in one machine. In addition to machine vision technology, Omron also developed the control and parts of the drive system. Both were selected according to the criteria reliability, speed and precision. The high proportion of technology from one source is thus also the main advantage of the inspection system.

The system is particularly economical for all inspections which require not only few random samples but large numbers of work pieces and a quality level at 100%. The advantages of an automated solution lie in the clear definition of good products as opposed to rejects. In this way, the same high quality standard is achieved for all inspected parts, which would not be possible by manual inspection.

► **Author**
Christian Wölz,
Managing Director ICW

► **Contact**
Omron Electronics GmbH
Langenfeld, Germany
Tel.: +49 2173 6800 0
Fax: +49 2173 6800 400
info.de@eu.omron.com
www.industrial.omron.de

ICW – Ingenieurbüro Christian Wölz
Friedberg, Germany
Tel.: +49 821 6099 526
Fax: +49 821 6099 531
info@icw-news.de
www.icw-news.de



Lösungen für die Bildverarbeitung



Telezentrische
Objektive

605 Objektivserien sofort verfügbar

Telezentrische Objektive,
Festbrennweiten, Mikrovideolinsen
und vieles mehr

Kompakte Objektive mit
Festbrennweite



µ-Videolinsen



**BENÖTIGEN SIE BERATUNG?
KONTAKTIEREN SIE UNS ODER
FORDERN SIE EINEN
KOSTENLOSEN KATALOG AN!**

Kontaktieren Sie unsere Experten.

Mehr Optik | Mehr Technologie | Mehr Service

ed **Edmund**
optics | worldwide

USA: 1-856-547-3488 | www.edmundoptics.com
EUROPE: 49 (0) 721 6273730 | www.edmundoptics.de
ASIA: 65 6273 6644 | www.edmundoptics.com.sg
JAPAN: 81-3-5800-4751 | www.edmundoptics.jp

Found Despite the Camouflage

Layout Independent Fault Detection of Circuit Boards by AOI Systems with Angled-view Inspection



Systems for the automated optical inspection (AOI) have become an essential element in the PCB production process for guaranteeing a reliable quality assurance. In order to control the PCBs independently of their layout and assembly parameters, a high-end angled-view inspection is indispensable. However, such a module is not easy to develop, as Goepel electronic knows from experience.

Lifted Leads belong to the most critical faults in the production of PCBs. They result e.g. from lifted pins or from insufficient wetting through the pin's oxidation. In the electrical test they may perfectly show an electrical contact to the pad on the PCB – however, in the actual use there can be discontinuities and hence a malfunction of the PCB. These Lifted Leads

not only belong to the category of critical faults, moreover, they are very complex to detect due to their diversified appearance. Numerous parameters affect the quality of the solder joint and the Lifted Lead. These include length and width of the pad in the same way like height of the pin and the solder properties: the flow behavior, the quantity and the solder flow at the pin

foot. All these criteria are combined in reality so that there are a variety of possible appearances. In the daily use there may be Lifted Leads that are detectable with orthogonal inspection, however, this is significantly dependent on the PCB layout and the applied solder quantity.

An Angled View Is not Enough

In the field of inspection systems, the angled-view is considered as the solution for maximum fault detection. However, a critical approach to the AOI systems is necessary as a range of parameters have different impacts on the performance:

The **field of view (FOV)** of the angled view is responsible for the inspection speed of the complete system. As a comprehensive use of the angled view is necessary for the inspection of complex PCBs with a high number of ICs, the FOV is decisive for the time of inspection.

The **depth of focus and the image quality** of the angled view is also decisive for the whole FOV on the PCB as well as in regard to the height extension of the components. Consequently, it influences the inspection quality and speed. The sole evaluation of the front menisci at pin solder joints has a limited informative value regarding the solder quality. An angled inspection of the IC pins enables an optical inspection that resembles an IPC-conform test much more.

Sufficient Resolution

Especially for the inspection of fine pitch ICs up to 0.3 mm a sufficient resolution is necessary for safe fault detection. If there

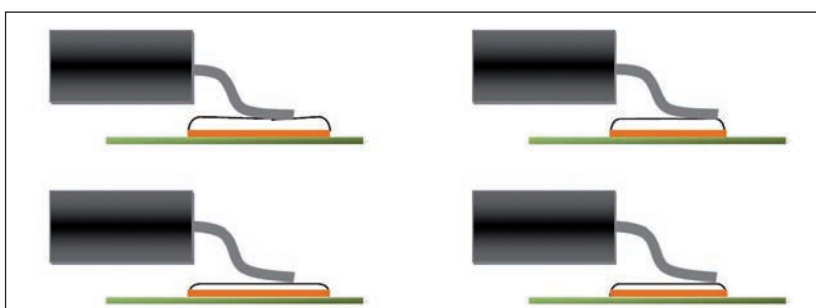

Examples of possible appearances of Lifted Leads

Angled-view module Chameleon for the integration in AOI systems of the OptiCon series ▼

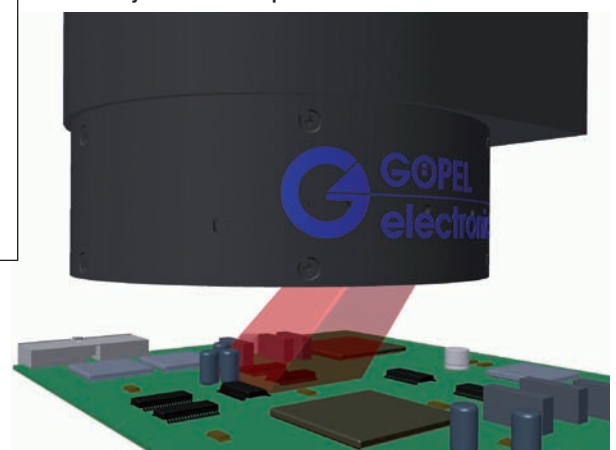

「INNOVATION AND SOLUTIONS」 push the button

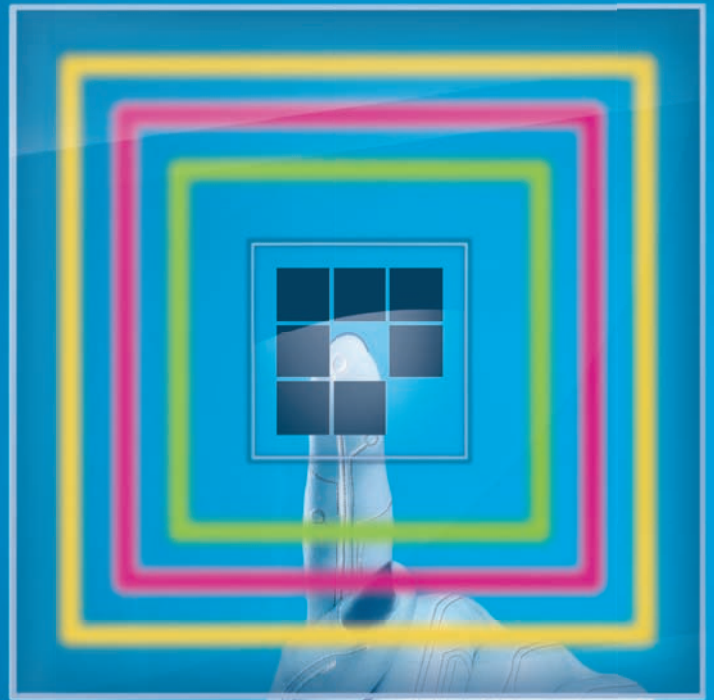

 **AUTOMATICA**
INNOVATION AND SOLUTIONS

4. Internationale Fachmesse für
Automation und Mechatronik

8. – 11. Juni 2010 | Neue Messe München

www.automatica-munich.com





AOI systems of the OptiCon family, optional available with rotating angled-view module Chameleon

are higher components in front of the tested pins there might be overlaps in the angled field of view. One tries to evade this situation with design regulations, however, this is a question of practicability.

A deflexion of the PCB during the inspection process might cause a displacement of the inspection positions in the camera image of the angled-view. In order to counteract this effect adequate compensation algorithms can help.

Components in an angled position other than the 90°-steps cause higher efforts regarding the programming time, because the test samples are not defined in the library (test units, macros etc.). So, a manual adaptation is necessary.

Besides the image capturing using angled view, an intelligent verify function is necessary in order to reach a safe fault detection with minimum false call rate under the above named circumstances.

Supported by Customers

As a basis for the development of a powerful angled-view module, Göpel electronic prepared a catalogue that contains all appearances of Lifted Leads and their combinations. Based on this catalogue, all classes of appearances were backed up by real samples in close cooperation with customers. The result is a pool of thousands of Lifted Leads in different appearances. Based on this, a method of

image capturing was identified by modifying the directions of viewing and illumination, which ensures the detection of all catalogued Lifted Lead variants.

According to the requirements of the image capturing, an angled view module was developed that is distinguished by a big field of view (42 x 42 mm) with a high image quality and depth of focus, as well as a resolution of up to 10.5 µm/pixel. On the basis of the images captured in this way, an algorithm was developed that enables the automatic detection of Lifted Leads under all circumstances. Thereby, the solder joint inspection close to IPC was paid special attention to. That is only possible due to an angled-view inspection of the IC pins. This approach, using an intelligent optical design, allows the simultaneous inspection of two opposite pin rows of an IC. Hence, there is a significant advantage in the inspection time as e.g. for an SO-IC image capturing from only one direction is necessary. Even for components with four pin rows, there are only two inspections necessary with one 90° rotation of the viewing direction.

Verification of the Algorithm

The final verification was successful: All available real Lifted Lead samples incl. the application in production are detected at 100% without increasing the false call rate. The application in critical

assembly situations was also considered in the development of the angled-view module (e.g. covering by higher components) along with the inspection of components in any angular position. Due to these considerations, the rotatability in 1° steps over an area of 360° was integrated in the module.

The benefit for the user is demonstrated in the following points: For components in different angular positions (e.g. 20°) no adjustment of the inspection position or the parameters is necessary as the viewing direction has only to be adjusted to the respective angular position (e.g. 20°), and the inspection can be carried out using a standard library sample in 0° position. If the viewing direction is obstructed by components, it is possible to turn the viewing direction for a few degrees until the solder joints are completely visible. Consequently, a reliable fault detection is guaranteed.

Summary

For assuring highest quality demands in the production of PCBs a powerful angled-view inspection guarantees layout independent and safe fault detection. The size of the captured field of view influences the inspection speed of the AOI system significantly. The free rotation of the viewing direction in an area of 360° allows an easy inspection of solder joints that might be covered by components in front of them.

A modular integration into in-line and stand-alone AOI systems allows the module to be used for a significant quality increase even for smallest batches.

▶ **Author**
Jens Kokott,
Manager AOI/AXI systems



▶ **Contact**
Göpel electronic GmbH, Jena, Germany
Tel.: +49 3641 6896 0
Fax: +49 3641 6896 944
sales@goepel.com
www.goepel.com



Quality Assurance in Aluminum Strip Production

Hydro, a European aluminum producer, implements a comprehensive quality management system at Grevenbroich works. Therefore, the company equips two process lines with Cognex surface inspection systems and data

integration software from QuinLogic. The systems will check the quality of the strip right before the dispatch to the final customers. The products must not be released for shipment to the customer unless also quality data from process steps upstream of the strip coating process are taken into account. The interactive strip protocol developed by QuinLogic combines data from upstream process steps, providing a reliable basis for a holistic approach to strip quality assessment. The evaluation is an interactive, cooperative process involving several people who assess the quality based on different criteria in a successive process. From now on, this will be supported, consolidated and documented.

QuinLogic GmbH · Tel.: +49 2405 479994 0 · info@quinlogic.de · www.quinlogic.de

Inspection of Thin-film Solar Modules

Basler's Sencis thin-film inspection solutions help manufacturers in the solar industry to improve operations in the various steps of their production process, reduce module breakage rates and, consequently, improve the quality of their thin-film modules and lower the cost of manufacture. Sunfilm has integrated three in-line metrology solutions from Basler Vision Technologies into their thin-film line for photovoltaic modules. These solutions are used for glass inspection, CVD coating inspection and end inspection. Sunfilm not only inspects incoming glass, but also ensures highest quality of the semiconductor coatings on thin-film modules and of the final product after the lamination process is finished. This 100% quality inspection secures Sunfilm a decisive competitive edge.

Basler AG · Tel.: +49 4102 463 0 · info@baslerweb.com · www.baslerweb.com

Industry Partner in the Hiflex Project

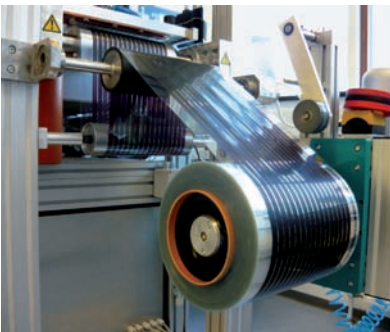
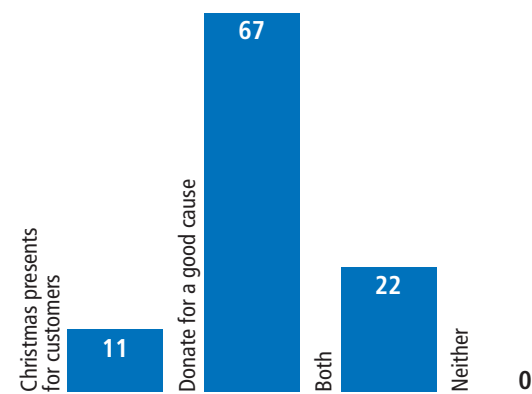

Photo: courtesy, F. Krebs, RisO DTU

The company Dr. Schenk announces its participation in a trend-setting research project supported by the European Commission. The Hiflex project aims to jointly develop a technology for highly flexible organic Photovoltaics (OPV) modules. Due to the use of commercially viable printing and coating techniques on roll-to-roll material, this new PV generation can be produced more cost-effective than today's solar modules. The research consortium has selected Dr. Schenk as industrial partner for the Hiflex project. The company contributes its highly recognized and valuable know-how in the production processes of thin-film PV modules as well as roll-to-roll material and their quality requirements.

Dr. Schenk GmbH · Tel.: +49 89 85695 0 · info@drschenk.com · www.drscenk.com

Should companies give Christmas presents to their customers or rather donate for a good cause?



Quelle: Inspect-Online



High Quality for Stainless Steel Production

Isra Parsytec, provider of surface inspection systems for strip products, received a purchase order by the stainless steel manufacturer for a surface inspection system at their Annealing Pickling (APF) line as well as a full license for the Quality Yield Management software. The Thai stainless steel producer ThaiNox Stainless, manufacturer and distributor of premium cold-rolled stainless steel sheets and coils, chose to equip his cold annealing-pickling line at their production site in Rayong with the state-of-the-art inspection system espresso SI. Not only the lean hardware convinced ThaiNox, but more importantly the user-friendly setup and operator software, which enables achieving valuable production benefits on the market shortly after installation.

Isra Vision Parsytec AG
Tel.: +49 241 9696 0
info@isra-parsytec.com
www.parsytec.com

FALCON

LED LIGHTING SYSTEMS FOR MACHINE VISION
Falcon LED Lighting Ltd. · Fasanweg 7 · 74254 Offenau
Web: www.falcon-led.de · Phone: 0(049) 7136 9686-0

Z-LASER

Zuverlässige Lasermodule
für Anwendungen von
Bildverarbeitung bis Wissenschaft

www.z-laser.com

Weitere Informationen:
www.z-laser.com
Tel. +49 / 761 / 296 44-44

Rotating Tubes

Length and Speed Measurement for Non-contact Quality Inspection of Tubes

For the quality control of steel tubes several non-destructive testing methods are combined to achieve fast and complete inspection of the tubes. For the associated necessary length and speed measurement of the rotating tubes usually several Laser Velocimeters are used. In this way clear and distinct position data of the tube is available during the entire inspection process.



Manufacturers use non-destructive testing methods to inspect seamless steel tubes as different as E.M.I. (Electromagnetic Interference) testing, magnetic powder testing and ultrasonic testing. In particular the latter is adopted for the detection of different defect types along the complete length and the complete perimeter of the tube. Especially the detection of longitudinal and transverse defects as well as the detection of laminations and wall-thickness measurements are important quality relevant tasks. For defect localization the actual test method is combined with other measurement methods as for instance Laser Surface Velocimetry. This measurement technique is based on the Laser-Doppler principle and evaluates back scattered laser light to exactly determine the motion state and the momentary tube position in the inspection line. This combination of methods allows for a fast and complete test cycle of the tube and thus ensures a guaranteed product quality level.

Installations in Ultrasonic Test Stands

In ultrasonic tube inspection lines several Laser Surface Velocimeters are used to measure speed, length and position

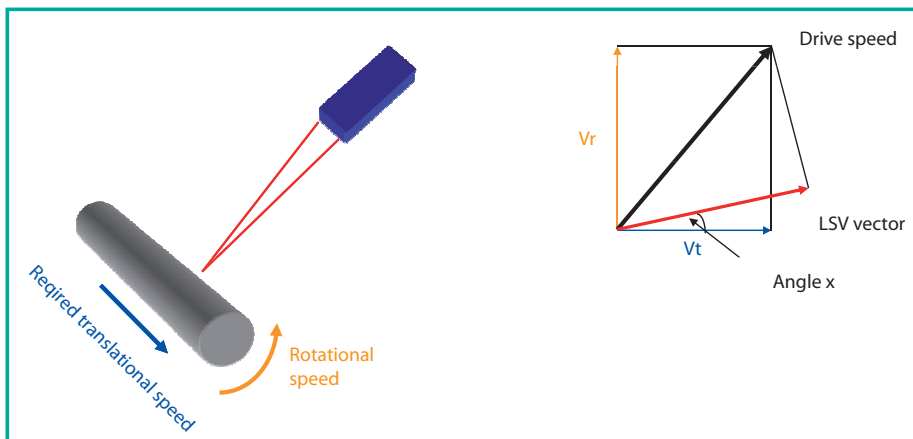

Superposition of translational and circumferential velocity

The Measuring Principle of Laser Surface Velocimetry

Laser Doppler Velocimeters are non-contact measurement systems used to make velocity and length measurements on moving surfaces, such as steel sheets, film, paper, textiles and other webbed material. These highly sophisticated measuring instruments operate on the Doppler principle which states that light scattered from a moving object is frequency shifted proportional to the speed and direction of the object relative to the observer (detector). Laser Surface Velocimeters measure this frequency shift. From this shift value, the instantaneous surface velocity can be calculated. Polytec velocimeters use a modified Doppler technique to measure an object's in-plane motion orthogonal to the instrument's optical axis. This technique superimposes two laser beams, separated in angle by 2φ , on the measurement surface. The optical axis bisects the separation angle and is aligned perpendicular to this surface. The overlapping laser beams form an interference fringe pattern on the surface. Surface velocities orthogonal to the fringe pattern are measured from the modulation frequency of the scattered light collected by the photo detector located along the optical axis. Polytec's LSVs are based on the sophisticated heterodyne detection method. Unlike conventional non-contact methods which measure only the absolute value of the velocity, Polytec's velocimeters are able to detect changes in direction and even standstill conditions. The measurement precision is fine enough that minute motions can be accurately measured.

The non-contact optical measurement process allows very high accuracy. It can be applied in complex measurement tasks, where tactile sensors can not obtain any measurement data or only with great difficulty, such as measurements on red-hot objects. Thus in continuous casting systems, e.g., Laser Doppler Velocimeters replace the measurement rollers traditionally used for measuring casting lengths and velocities. Thanks to the non-contact measurement process, slippage, scaling deposits or damage to bearings no longer affect the results of the measurement as they did when using measuring wheels.

Since Laser Surface Velocimeter Systems work on almost any surface, this measurement method is applied not only in the metals industries but also in many other application fields as in the production of wire and cable and in the processing of non-metallic materials as paper, wood, building materials and textiles.

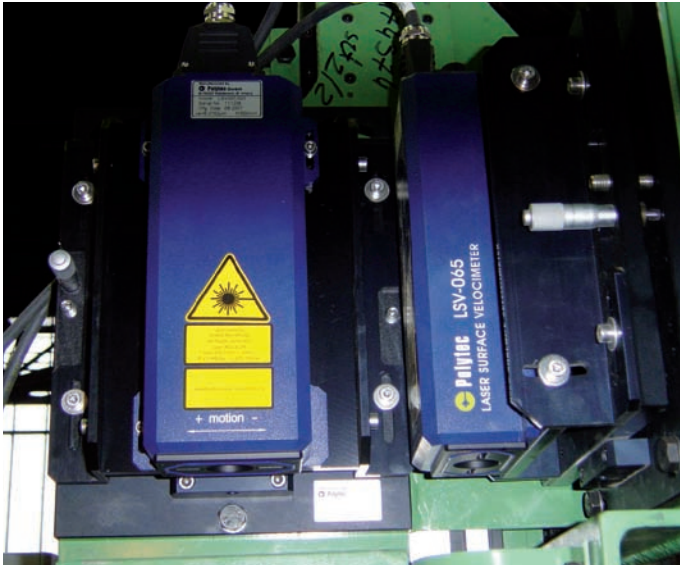

Configuration of LSV-065 sensor heads and fine-adjustment devices for measurement of translational (left sensor) and circumferential speed (right sensor) of the tube

(see separate box for explanation of the measuring principle). The tubes are rotating typically with about 2 m/s at maximum around their symmetry axis. At the infeed and at the outlet of the test line there are two pairs of LSV-065 Velocimeter measurement heads, which measure the axial motion of the tube and simultaneously the rotational motion perpendicular to the axial feed motion. The combination of two pairs of sensor heads at the infeed and outlet directly before and after the ultrasonic sensor allows for unambiguous measurement data of the exact position of the tube in the inspection facility. Since the axial feed velocity is much smaller than the circumferential speed of the tube rotation a precise alignment of the measurement direction of the sensor head parallel to the forward motion is absolutely crucial to avoid any superposition with the rotational motion. Otherwise, a too high or too small infeed velocity would be measured and consequently would lead to an error in the length measurement and in the position. The necessary alignment quality is accomplished by a high-precision mounting and

adjustment platform which uses micrometer adjustment screws to precisely set the angular position for a perfect alignment.

Non-contact and Precise

Combined with appropriate accessories Laser Surface Velocimeters enable precise, non-contact length and speed measurements even in the case of perpendicular superimposed motions. The accuracy of the length measurement that can be obtained generally and which is also realized in the case described here is better than 0.1%. In this special case of two superimposed motions with large velocity differences and the need for independent determination of the velocity components this value for the length measurement accuracy is more than satisfactory.

► **Author**
Dr. Heinrich Steger,
Strategic Product Management

► **Contact**
Polytec GmbH, Waldbronn,
Germany
Tel.: +49 7243 604 0
Fax: +49 7243 699 44
info@polytec.de
www.polytec.de

Piezo · Nano · Positioning

PI

Alternative Antriebe



PILine® Hochgeschwindigkeitsantriebe

- Stellkraft bis 10 N
- Geschwindigkeit bis 500 mm/s
- sub- μ m-genau



NEXACT® PiezoWalk® Kompakte Präzisionsantriebe

- Stellkraft bis 15 N
- Geschwindigkeit bis 10 mm/s
- sub-nm-genau



NEXLINE® PiezoWalk® Hochlast Präzisionsantriebe

- Stellkraft bis 500 N
- sub-nm-genau
- Hochdynamisches Regeln

Kompakt, kraftvoll, hochauflösend – Piezolinear-antriebe bieten unbegrenzte Stellwege und sind prinzipiell vakuumtauglich und nichtmagnetisch. Im Ruhezustand selbsthemmend, vermeiden sie Erwärmung durch Halteströme sowie Servo- oder Mikroschritt-Zittern.

Fragen Sie uns: **HMI, Halle 6 – Stand J32**

Physik Instrumente (PI) GmbH & Co. KG · Tel. 0721 4846-0

Wir öffnen Nanowelten | www.pi.ws

Good Quality?

InGaAs Image Sensor Hybrids for Industrial Applications

Near-Infrared images (900 nm ... 2,200 nm) allow to distinguish between objects that look quite similar in visible light. Thus quality criteria are detected that otherwise would remain invisible. Available NIR image sensors so far have been expensive and hard to manage, with rather low resolution and fairly high noise. Now there are new developments: Sensors based on Indium-Gallium-Arsenide in combination with CMOS readout technology.



Impressions from Thuringia/Germany – taken with an InGaAs-camera (Source: ABS GmbH, Jena)

When choosing the best apple from the basket, the hand moves almost automatically towards the flawless shiny surface. But if there are bruises underneath, the customer does not see. The InGaAs (Indium-Gallium-Arsenide) sensor, however, does: It is sensitive in the range of wavelengths, where water has its absorption maxima, at 1,450 nm and 1,950 nm. A bruise or an old apple holds less water which influences the absorption and reflection properties of the apple's surface. These changes can be detected by the InGaAs sensor. Based on this method, not only the quality of food can be inspected, but process gas analysis, paper and carton inspection, or the surveillance of vegetation growth is possible as well. Other examples for the usage of InGaAs sensors are the analysis of skin-moisture and skin-ageing or the inspection of airplane outer surfaces during de-icing processes in winter times. For a number of materials near infrared light penetrates deeper into the material than visible light, this enables a better inspection of deeper layers near to the surface. There are materials, e.g. Silicon, which are completely transparent for near in-

frared light rendering semiconductor inspection applications possible as silicon-wafer inspection, solar cell inspection, MEMS package analysis, and many more.

Even if the list of applications seems to be quite long, the price of InGaAs-technology has so far prevented a broader proliferation and use for industrial applications. Although the prices of InGaAs imagers have decreased consistently as well, the InGaAs-hybrid prices will still not be comparable to Si-CMOS imagers any time soon. That is why InGaAs-technology has to provide a substantial qualitative advantage for the inspection applications to be considered and accepted by the industrial user. This is the case, however, for many of the applications mentioned above.

InGaAs Hybrid Technology

Semiconductor material InGaAs is a ternary AIII-BV semiconductor for the spectral range from 900 nm to 1,700 nm and is thus generally usable for all light-detection applications in that spectral range. In order to help the camera manufacturer integrating the InGaAs image sensors into the camera-electronics, Andanta offers sensors being coupled with a CMOS read out integrated circuit (ROIC). The InGaAs photodiode array and the ROIC are tightly connected by means of an Indium-bump-bonding technology. At the output, the sensor provides an amplified analogue signal for further processing by the camera-electronics. The integrated electronics provides numerous features as choice of various operational and integration modes, of number of outputs, adjustable integration time and bandwidth. Also



fast read out of partial images (Region of Interest), skimming (offset suppression) and internal test functions are included.

Default Mode for a Fast Start of Operation

In preset default mode the user works with just one output out of four. Four digital input-clocks (CLK, FSYNC, LSYNC, FIELD) are used, while a control register (for the advanced user) remains without signal. This mode only allows reading out full images in interlaced mode. Amplification gain and input bandwidth of the sensor are variably adjustable. As a result, the default mode allows a fast start of operation by the camera developer at reduced expenditure, low power consumption and moderate read out rate.

Modes for Professionals

The full performance of the sensor only unfolds, though, when using the control register. In this control mode the number of outputs can be chosen from one to four and partial images can be read out (ROI),

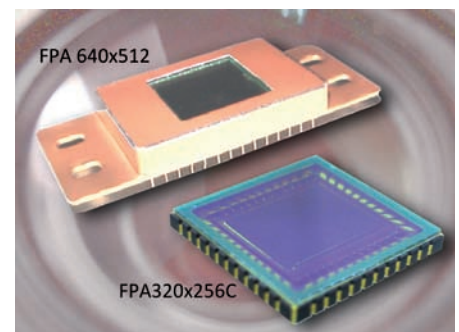

InGaAs standard housings – cooled and uncooled

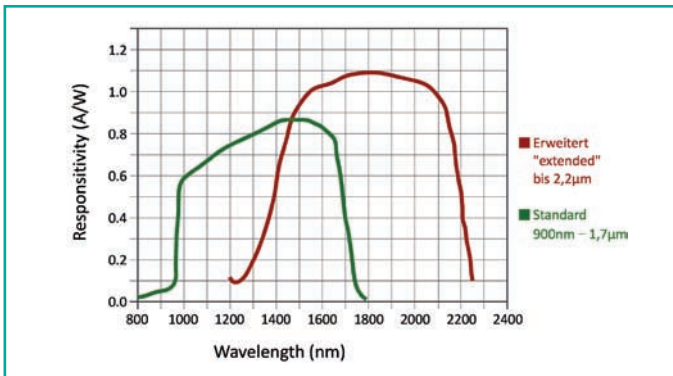

InGaAs-Spectral Response Curve, standard (900–1,700 nm) and extended (1,200–2,200 nm)

while the size and location of the read-out window is selectable. Furthermore, the image information, once integrated, can be read out multiple times and the sequence of single pixel readout is adjustable as well. Thus, the sensor concept ensures a high degree of flexibility for the user. Depending on the application one will use a suitable sensor operation and integration mode:

- For a **fast application** a lower sensor resolution will be advantageous (320 x 256) and the controlled mode with four outputs will be chosen, while using the „Integration while Read“ (IWR) mode. Additionally, using of Region of Interest (ROI) operation can be considered, which allows a read out rate of up to 14 kHz.
- For a **high sensitivity application** the user will choose a thermoelectrically cooled sensor and puts the gain on „high“ for reducing the noise floor down to about 45 e-.
- When implementing a **high-resolution application**, the sensor with the highest standard resolution, FPA640x512, will be chosen. Even higher resolution sensors can be developed in the frame of a custom-specific contract.

All sensors are pluggable to commercially available sockets as well as solderable. For



Water Absorption at Wavelength 1,300 nm (lab image)

(Source: ABS GmbH, Jena)

most of the industrial applications standard lenses are applicable.

Standard Products and New Developments

The standard InGaAs matrix arrays feature a 320 x 256 and a 640 x 512 pixel resolution for the spectral range of 900 nm to 1,700 nm. If the device is thermoelectrically cooled, it comes in a hermetic 28-pin Kovar package with one-stage thermoelectric cooler and sapphire window. For the lower resolution matrix with 320 x 256-pixels there is also an uncooled version available using a hermetic 44-pin ceramics package with sapphire window. The uncooled version forms a good entry into InGaAs-techniques for the starting user. It can be operated at ambient temperature; the device is compact and easy to integrate. The low power consumption and low mass also make it suitable for

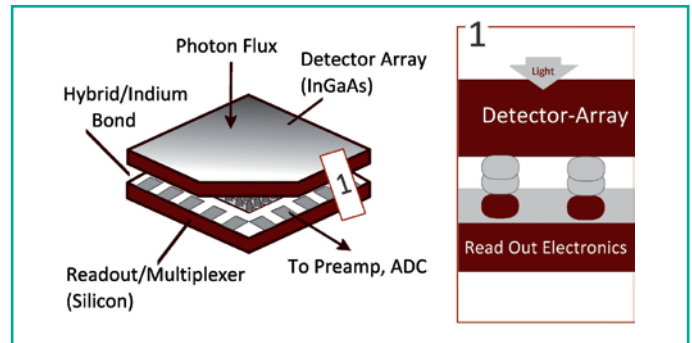

InGaAs Hybrid – simplified diagram

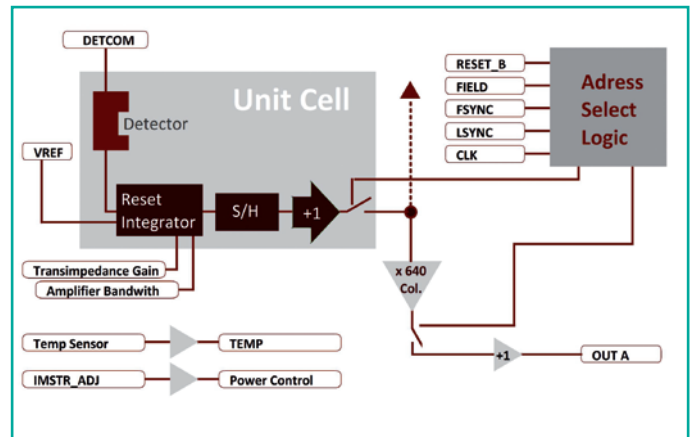

Integrated CMOS electronics – block diagram for preset Default-mode

portable inspection and night vision applications.

Extension of the Spectral Range

The spectrally extended sensors for the wavelength range of 1,200 nm to 2,200 nm are, for reliable infrared operation, exclusively delivered in 28-pin Kovar package with one-stage thermoelectric cooling.

Extending the spectral sensitivity into the visible part of the spectrum (VisGaAs), below the wavelength of 900 nm, is part of a developmental program currently ongoing. Developing even higher resolution standard devices, e.g. with 1,024 x 1,024 elements, is considered as well. Technologically such a sensor would be feasible already today, but the higher sensor price might not be attractive enough for the industrial user.

The Andanta InGaAs matrix arrays feature a very good price performance ratio. Therefore they are attractive for camera manufacturers as well as for manufacturers of spectrometers, analytic measurement devices and other scientific optoelectronic systems for industrial inspection. The system developer will get extensive help when designing-in the image sensors. The sensors are also long-term available and not threatened easily by obsolescence.

► **Author**
Christian
Lochmann,
Managing Director



► **Contact**
Andanta GmbH, Olching, Germany
Tel.: +49 8142 487658
Fax: +49 8142 487659
christian.lochmann@andanta.de
www.andanta.de



Quelle: Universität Frankfurt

In the Accelerator

Visual Control of Welding Processes

Currently, a particle accelerator is being set up at the Heidelberg Cancer Research Center. It combats brain tumors using heavy ion radiation. But the newly developed accelerator chamber is designed in such a difficult manner that for a long time, the researchers have not found any production company which was able to manufacture the required welded stainless-steel structure. The challenge lies in the hidden welding points.

Certain previously inoperable brain tumors can be combated in an astoundingly gentle manner using heavy-ion radiation. A pilot project conducted by GSI Darmstadt (Helmholtz Centre for Heavy Ion Research) together with the Cancer Research Center Heidelberg has demonstrated this. Parts of the Heidelberg accelerator were developed at the Stern-Gerlach Center under the leadership of Ulrich Ratzinger and Alwin Schempp. "In

two years, the largest scalpel in the world will also be used to treat patients in Heidelberg," explains Alexander Bechtold, one of the researchers of Ratzinger's team. The team is already working on smaller and more powerful successor models of the accelerator components. True to the working title "Low Energy

Transport of an Incoherent Proton Beam," the researchers developed an accelerator chamber whose performance will far exceed that of previous models. But the final design is so difficult that no production company has yet been found that is willing to build the welded stainless-steel structure.

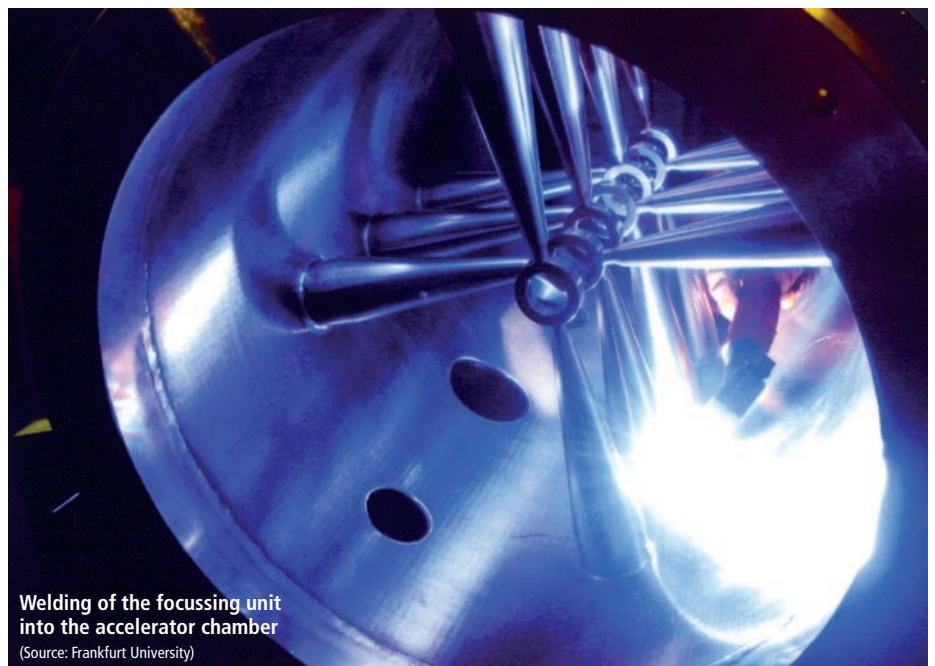

Welding of the focussing unit into the accelerator chamber
(Source: Frankfurt University)

Construction Mechanics Specialists

The assembly that is to be manufactured is a tube approximately 1.5 m long and 40 cm in diameter, in which conical constructions radially fix the focusing and accelerator units with a spacing of approximately 10 cm. At the manufacturing process the surface has to keep very smooth to ensure a uniform copper-plating. Moreover, the unit must be extremely vacuum-tight. Surfaces must be permanently resistant against the cooling media flowing in the hollow spokes to the focusing units. For these requirements the most appropriate welding method is a manual MIG welding. The points that are to be welded are difficult to visualize owing to the design of the structure. It is not possible for the welder to access the depth of the tube with his head while wearing a welding helmet.

Due to these complex requirements the Stern-Gerlach Center's researchers appeal to the Construction Mechanics specialists from Frankfurt University. This department of the university realizes special metal-working jobs. There, Jürgen Kölichhaus and his team attend to components or products which are too complicated or too labor intensive for external manufacture. Wolfgang Gass, a construction mechanic, developed a concept which essentially allows the production. But one problem stayed: Welding points that are hidden from direct visual observation. The welding specialist, however, is not permitted to work blind. If he were to do so there would be a high risk of not meeting requirements for surface quality and tightness.

Camera Concept for Visual Inspection

Tests with optical systems or mirrors to bring these welding points into the field of vision of the welder remained unsuccessful due to the large distances and strong impairments of vision through reflections inside the shining stainless steel structure. Inquiries addressed to welding institutes also failed to turn up any satisfactory solution to the problem until the team found the company hema electronic with its camera system suited for the job. Their seelectorICAM weld has a unique concept for recording and displaying the very high differences in brightness. To control the process, the welder has to be able to visualize the arc, the puddle and the surrounding area as precisely as he would with his own eyes through the welding helmet. Initial tests on a simple sheet-metal model showed: With a little

practice the welding specialist can use the monitor to keep the visual control for the manual guidance of the torch.

After these successful initial tests, hema electronic, camera specialist based in Aalen, Germany, put together a complete package made up of camera, notebook computer and additional 10" monitor.

Welding Seams Fulfill Requirements

Bastin Chakkalamattah, the welding specialist who conducted the tests, says: "It requires a little practice to master the eye-hand coordination, but the sharp images of the camera allow me to monitor the process visually at any time. I can see very precisely the arc, the puddle and the surrounding area. Therefore I know whether and how the process is going."

A first prototype of the new accelerator tube has since been constructed and the X-ray check of the welding seams created with the help of the seelector-ICAM weld show faultless and perfectly executed welds. After proof was provided that the manual welds made using camera monitoring meet the extremely high requirements, the accelerator chamber is scheduled to be constructed this year.

The head of construction mechanics, Jürgen Kölichhaus, says: "No commercial business would have been willing to risk building this accelerator chamber – and without the hema camera seelector-ICAM weld, we would not have managed to do it either."

► **Author**
Oliver Stoll,
Sales & Marketing



► **Contact**
hema electronic GmbH, Aalen, Germany
Tel.: +49 7361 9495 0
Fax: +49 7361 9495 45
info@hema.de
www.hema.de

Institute of Applied Physics, Frankfurt University,
Germany
Prof. Dr. U. Ratzinger
Tel.: +49 69 798 47404
u.ratzinger@iap.uni-fankfurt.de

ERFOLG DURCH QUALITÄT
2010
24. Internationale Leitmesse
für Qualitätssicherung

Control



Forum

- Messtechnik
- Werkstoffprüfung
- Analysegeräte
- Optoelektronik
- QS-Systeme
- Organisationen
- Industrielle Bildverarbeitung



4. - 7. Mai
STUTT GART

Direkt am Flughafen und Autobahn **A8**

SCHALL
MESSEN FÜR MÄRKTE.

P.E. Schall GmbH & Co. KG
Tel. +49(0)7025.9206 - 0 · control@schall-messen.de

www.schall-virtuell.de

www.control-messe.de

Mastering Challenging Requirements

Accuracy of Fuselage Panel Machining Is Ensured by 3D Laser Scanner



Engineered to replace the ecologically stressful chemical machining of aluminum panels that was previously used to reduce aircraft structural mass, the groundbreaking five-axis machine tools use a system of dual mirror spindles, with one spindle for cutting and the other for holding the work piece as if it were a mobile table, with complete freedom of movement in five continuous axes. All roughness and geometry targets are achieved on a single machining station. The high-speed metal-cutting technology is economical; the Mirror Milling System (MMS) machines are built according to strict specifications so as to produce all fuselage components within competitively short cycle times.

Ensuring Passenger Safety

With passenger safety at stake, quality inspection is a major concern for all involved in this project. Once the aluminum panel and milling tools are loaded and fixed in the machine tool, the Kreon Zephyr scanner is used to locate the exact 3D position of the panel in space, digitizing with laser triangulation technology. Scanning 30,000 points each second, it collects data on the produced part, and then recreates it as a 3D model. In the next step the geometry of the panel is compared to the theoretical CAD profile

The French manufacturer of large-scale machine tools Dufieux Industrie has collaborated with Airbus within the framework of a European program to develop an innovative and environmentally friendly technology for mechanical machining of large aluminum airframe components. Machining of the fuselage skin panels requires extreme accuracy and tight tolerances, and the custom machine tools developed by Dufieux Industrie are gargantuan. Key to producing the extra-thin panels with the necessary accuracy is an inspection system built into each of the 14 x 10-m machines that incorporates a 3D laser scanner manufactured by Kreon Technologies.

of the finished part, and any deviations that are identified can be immediately corrected.

As soon as machining is completed, the panel is trimmed and unloaded for off-machine inspection. The stability of the machine's massive, rigid frame ensures accuracy in both, machining and quality inspection.

Versatile Scanning Technology

The benefits of the Kreon laser scanning technology in this critical application include fast, accurate data acquisition, representation of deviations, and seamless integration into the five-axis machining centre and associated software, not to mention the integration expertise and support provided by the Kreon engineers. On the five-axis MMS machining centre, the Zephyr scanner demonstrates a versatility that is characteristic of all of Kreon's 3D laser scanners.

In order to make the fuselages of the aircraft as light as possible so that more

flying weight can be in the form of cargo, the system that emerged from the development program can process all types of sheet metal with a maximum section of 12 mm into panels that are as thin as 1.2 mm in some areas after machining, with tolerances ranging up to $\pm 1/10$.

Four of these flexible, sophisticated five-axis machining units that incorporate Kreon's 3D laser scanning technology are operating around-the-clock at Airbus production sites.



Zephyr is scanning a part of the Airbus A380

About Kreon

Based in Limoges, France, Kreon Technologies has a long history of integrating 3D laser scanning technology to CNC machine-tools. Ever since the company's establishment in 1992, Kreon engineers have been demonstrating their expertise in integrating their patented and innovative 3D laser scanning technology to suit the most complex and binding end-user environments. This includes CNC machining centers from Fanuc, Heidenhein, Fidia, Bridgeport, Fagor, Dynapath, Anilam, Charlyrobot, Gambin, Sharnoa, CMS but also 3D coordinate measuring machines, robots and 3D portable measuring arms.

► **Author**
Christophe Gabeau,
Sales Manager



► **Contact**
Kreon Technologies, Limoges, France
Tel.: +33 5 55 42 80 40
Fax: +33 5 55 42 80 08
info@kreon3d.com
www.kreon3d.com

Fluorescent LED Line Light Lotus

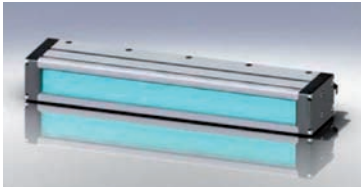

The Lotus was designed by StockerYale's R&D division to provide an alternative solution to fluorescent illumination for use in Machine Vision applications. The line light has a unique design which utilizes the latest LED technology combined with an integrated optical system which increases the intensity and extends the working distance. It provides a stable and uniform factory-set light output and features high energy efficiency with an integrated power control.

Lotus runs five years long with maintenance free operation. The flexible design ensures the light to be compatible with both back lighting and front lighting web applications, providing a broad and uniform beam which is consistent across webs as wide as 5 m.

Laser 2000 GmbH · Tel.: +49 8153 405 0 · info@laser2000.de · www.laser2000.de

Confocal Sensors in Coordinate Measuring Machines

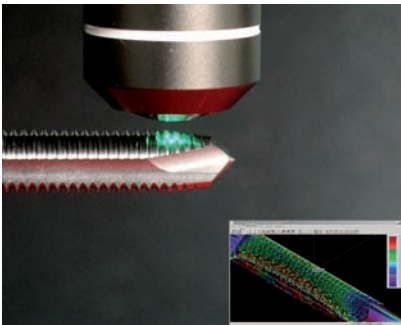

Werth Messtechnik presents the integration of a confocal surface sensor in a multisensor coordinate measuring machine, the Nano-FocusProbe NFP. The NFP is used for the measurement of the geometry, shape, and roughness of microstructures, but also for radii of cutting edges of tools, or for coating thicknesses. It can be used both in the lab and on the production floor. The integration of the NFP was implemented in cooperation with Nanofocus AG. The sensor is fully integrated in the Werth multisensor concept and allows small probing deviations of just a few tens of nanometers. With various optics, its capability with regard to accuracy and measurement range can be adjusted to suit the application.

Werth Messtechnik GmbH · Tel.: +49 641 7938 0 · mail@werthmesstechnik.de · www.werth.de

Brightfield Objectives for Industrial Imaging



Olympus has introduced the new Mplapon series of plan apochromatic objectives, which provide a high level of chromatic aberration correction for materials imaging. Completing the Olympus UIS2 objective range, the Mplapon objectives are available in 50x and 100x magnification. Developed to provide excellent brightfield imaging, including DIC, the Mplapon objectives feature numerical apertures (N.A) of 0.95 and are fully compatible with active auto-focusing units. This series is ideal for inspecting minute areas in industrial imaging samples, such as semiconductor patterns. For the production of the Mplapon objective range Olympus developed a new wavefront aberration control process. With this measurement device, small aberrations, not visible to the human eye, can be quantitatively measured and therefore eliminated to produce high-quality objectives with strel ratios of at least 95%.

Olympus Europa Holding GmbH · Tel.: +49 40 23773 0
microscopy@olympus-europa.com · www.microscopy.olympus.eu

Optimized Metal Strip Inspection



Measurement technology system supplier Micro-Epsilon has completely revised the design of its measurement system for metal strip: The new system for thickness and profile inspection now provides a measuring gap of 190 mm, three times larger than its predecessor. In addition, the system can now reliably measure corrugated and vibrating metal strip. Rather than using the previous point-type laser sensors, profile sensors are now installed, which measure significantly better on many different strip materials and which increase the monitoring range. The system enables thickness measurements to an accuracy of 0.01 mm and is used for process stabilisation, quality assurance and documentation. Due to

the use of a special high-tech light barrier, edge detection for warped strips is also possible. This enables robust width measurement with high reliability.

Micro-Epsilon Messtechnik GmbH & Co. KG
Tel.: +49 8542 168 0 · info@micro-epsilon.com · www.micro-epsilon.com

www.inspect-online.com

**WE'LL
DRAW
ATTENTION
TO YOU**



© lemywolf/fotolia.com

VISION · AUTOMATION · CONTROL ·····
INSPECT



Visionary

Interview with David Dechow, President of Aptúra Machine Vision Solutions

INSPECT: David, your company Aptúra specializes exclusively in machine vision systems integration. What exactly do you consider to be the role of the machine vision integrator in the value chain of a machine vision solution?

D. Dechow: Integration in machine vision is the point in the project where someone actually has to “make it work”. The integrator is an implementation resource in the market chain; a technology expert who designs, implements and supports an entire inspection system; not just the individual components.

The systems integrator is a partner who provides risk mitigation, eliminating concerns for project success. It is very common for the integrator to fully guarantee the performance of their machine vision systems.

The integrator is extremely valuable as a provider of outsourced engineering services in cases where a company is short of in-house machine vision expertise, or where the company simply can not allocate staff to execute a machine vision project in a target time frame.

The predominant term used by all machine vision producers describing their component or system is “easy-to-use.” Does this mean that the era of integrators will soon come to an end, since the end user will be perfectly capable of integrating all these easy systems by themselves?

D. Dechow: I am a big fan of machine vision systems being “easy-to-use.” How-

ever, let’s not confuse “easy-to-use” with “easy-to-program” or more importantly with machine vision expertise. Developing a successful machine vision application involves so much more than just the configuration of the machine vision tools. Expertise in the application of lighting, optics, imaging concepts is a critical factor in every project.

There have been “easy-to-use” machine vision systems in the marketplace for over 25 years. Vendors have used light pens, ladder-logic, touch screens, numerous menu structures, drag-and-drop icons, spreadsheets and even game controllers in order to provide a more user-friendly way of programming and configuring a machine vision application. I think that one may question somewhat whether these all have represented “ease-of-use.” The truly easy to use machine vision system is one that requires no programming at all! It comes pre-programmed to be completely suited for the targeted inspection task, yet allows the operator or end-user full access to key inspection parameters and inspection data. This is the kind of system that a competent machine vision integrator can provide.

What concerns me in the marketplace is the trend towards believing that all machine vision applications should require minimal integration. Driven by marketing, machine vision component vendors have successfully convinced many of the end-user community that machine vision only requires, in effect, a cheap camera with

integrated light source hung over an assembly line. The disturbing result is that companies either completely abandon or reduce the scope of a machine vision project if it can’t be done with a US\$ 5,000 camera with little or no programming. To be successful in the future, I believe that the machine vision industry needs to re-think the value proposition that is being presented to the customer, and emphasize the return on investment that machine vision can provide over a wider range of integrated solutions.

Early on you had joined your first company, Insight Integration, with a larger European company. Based on this in-depth experience what do you consider to be the main differences between North American and European factory floor automation with machine vision?

D. Dechow: An impression I share with many is that European automation systems often are built with more attention to detail and with greater quality than the “typical” automation system built in North America. To be fair, certainly there are many excellent automation providers in North America who also deliver very high-quality systems. But, it is no surprise that on nearly all factory floors that I visit there is some packaging, molding, assembly, or other automation system that has come from a European supplier. I’ve observed also that in general the typical European engineer seems to have a broader understanding

ries

of machine vision and how the technology is applied in industrial automation.

2009 was obviously not a very good year for the factory floor automation business in the US. What are your expectations for 2010?

D. Dechow: Absolutely, 2009 was really a disaster with respect to machine vision

business for many in the US. However, we did experience an upturn at the end of the year, and this seems to have been the case for many others in the industry. We've seen that business continue through the beginning of the first quarter, but it is not clear if it will continue through the middle of the year. Some say that the upturn is only a short-term correction that has been the result of manufacturers completely depleting their inventories in 2009. I am conservatively optimistic though that we will see continued, if only slow, growth through 2010.

Aptúra is the second company that you have founded, and the second company focusing on machine vision projects and solutions. What is it that fascinates you so much in this side of the business?

D. Dechow: Someone once called me a "serial entrepreneur." I don't know if that is true, but from the point in 1983 that a friend convinced me to quit my programming job and do machine vision systems development, I was "hooked." I enjoy the creative side of the application of the

technology, and as an integrator I really enjoy the diversity of the projects and industries that we serve.

When I decided to work in machine vision, I made a conscious decision that I would make this my career, and would excel at it and be the best I could be in this industry. This is a good example for young engineers or young people in general. Find a career that you can be passionate about, commit yourself to that career, and be the very best at it that you can be.

► Contact

Aptúra Machine Vision Solutions, LLC
Lansing, MI, USA
Tel.: +1 517 272 7820
Fax: +1 866 575 1583
ddechow@aptura.com
www.aptura.com

BUYERS GUIDE

AUTOMATION: MEASUREMENT, INSPECTION, IDENTIFICATION, GUIDANCE

EVENTS

REPORTS

VISION: COMPONENTS AND TECHNOLOGIES

WHITEPAPER

LEAD-GENERATION

NETWORKING

TREND TOPICS

WEBINARS

CONTROL: MATERIAL INSPECTION AND MEASURING INSTRUMENTS

JOB

ONLINE-ARCHIVE

INDUSTRY NEWS

INSPECT-ONLINE.COM

WEBCASTS

PRODUCT INFORMATION

RSS FEED

- ▼ **INSPECT**, the leading European cross-media information source for decision makers
- ▼ Make use of our online search engines for products, suppliers, technologies, applications, industry solutions, people, and much more

- ▼ Find feature articles, machine vision basics, interviews, reports and other data in our online archive of recent **INSPECT** issues
- ▼ Get in contact with your business partners directly by using the E-Mail request function



www.inspect-online.com

www.gitverlag.com

INSPECT

VISION • AUTOMATION • CONTROL

Active Silicon	20	German Industry & Commerce	10	NeuroCheck	25
Adimec	20	Göpel electronic	44	New Imaging Technologies	36
Adlink Technology	29	Harvest Imaging	8	OctoMedia	14
AlA Automated Imaging Association	8, 10	hema electronic	52	Olympus Europa Holding	55
Allied Vision Technologies	10, 17, 34	ICW – Ingenieurbüro Christian Wölz	42	Omron Electronics	42
Andanta	50	IDS Imaging Development Systems	10, 11, 26, 35	Opto Engineering	28
AOS Technologies	34	ifm electronic	27	Physik Instrumente	49
Applied Vision	8	Image Engineering	8	Point Grey Research	7, 35
Aptúra Machine Vision Solutions	56	Imperx	24	Polytec	48
Basler	10, 34, 47	IOSS	30	Qioptiq	8
Baumer	15, 33	Isra Vision Parsytec	47	QuinLogic	47
Boulder Imaging	10	JAI	36	Rauscher	3
Cognex	8, 9, 33	Kappa opto-electronics	32, 33	P.E. Schall	53
Dalsa	Inside Front Cover	Kreon Technologies	54	Shanghai Tycoon Company	14
Darmstadt University of Applied Sciences	16	Laser 2000	55	Softhard Technology	35
Deutsche Messe	15	Landesmesse Stuttgart	21	Stemmer Imaging	31, 33
Dr. Schenk	47	Leuze electronic	12, Front Cover	SVS-Vistek	34, 35
Edixia	39, Outside Back Cover	Linus Photonics	8	Tordivel	37, 41
Edmund Optics	43	Matrix Vision	33, 39	VDMA Verband Deutscher Maschinen- und Anlagenbau	6
EMVA European Machine Vision Association	Insert, Inside Back Cover	MaxxVision	28	Vision Components	34
EqcoLogic	20	Messe München	45	Vitronic	40
EVT Eye Vision Technology	36	Micro-Epsilon	5, 55	VRmagic	36
Falcon LED Lighting	47	Microscan Europa	36	Werth Messtechnik	55
Fraunhofer IOSB	8	MVTec Software	36	Z-Laser Optoelektronik	47
Fujinon Europe	18	National Instruments	35		

IMPRINT

<p>Published by GIT VERLAG GmbH & Co. KG Röblerstr. 90 64293 Darmstadt, Germany Tel.: +49/6151/8090-0 Fax: +49/6151/8090-144 info@gitverlag.com www.gitverlag.com</p> <p>Managing Directors Dr. Michael Schön, Bijan Ghawami</p> <p>Publishing Director Gabriele Jansen Tel.: +49/178/1755972 gabriele.jansen@wiley.com</p> <p>Editors Dr. Peter Ebert Tel.: +49/6151/8090-162 peter.ebert@wiley.com</p> <p>Andreas Grösslein Tel.: +49/6151/8090-163 andreas.grosslein@wiley.com</p> <p>Stephanie Nickl Tel.: +49/6151/8090-142 stephanie.nickl@wiley.com</p>	<p>Editorial Assistant Bettina Schmidt Tel.: +49/6151/8090-141 bettina.schmidt@wiley.com</p> <p>Scientific Advisor Prof. Dr. C. Heckenkamp Darmstadt, University of Applied Sciences</p> <p>Segment Manager Oliver Scheel Tel.: +49/6151/8090-196 oliver.scheel@wiley.com</p> <p>Sales Representatives Claudia Brandstetter Tel.: +49/89/43749678 claudia.brandst@t-online.de</p> <p>Manfred Höring Tel.: +49/6159/5055 media-kontakt@t-online.de</p>	<p>Dr. Michael Leising Tel.: +49/3603/893112 leising@leising-marketing.de</p> <p>Dirk Vollmar Tel.: +49/6159/5055 media-kontakt@morkom.net</p> <p>Production GIT VERLAG GmbH & Co. KG Christiane Potthast Claudia Vogel (Sales Administrator) Michaela Mietzner, Katja Mink (Layout) Elke Palzer, Ramona Rehbein (Litho)</p> <p>Reprints Christine Mühl Tel.: +49/6151/8090-169 christine.muehl@wiley.com</p> <p>Bank Account Dresdner Bank Darmstadt, Germany Account No. 0171550100 Routing No. 50880050</p> <p>Advertising price list from October 4th 2009 Specially identified contributions are the responsibility of the author. Manuscripts should be addressed to the editorial office. We assume no liability for unsol-</p>	<p>cited, submitted manuscripts. Reproduction, including excerpts, is permitted only with the permission of the editorial office and with citation of the source.</p> <p>The publishing house is granted the exclusive right, with regard to space, time and content to use the works/editorial contributions in unchanged or edited form for any and all purposes any number of times itself, or to transfer the rights for the use of other organizations in which it holds partnership interests, as well as to third parties. This right of use relates to print as well as electronic media, including the Internet, as well as databases/data carriers of any kind.</p> <p>Material in advertisements and promotional features may be considered to represent the views of the advertisers and promoters.</p> <p>All names, designations or signs in this issue, whether referred to and/or shown, could be trade names of the respective owner.</p> <p>Printed in Germany ISSN 1616-5284</p> <p>The English language ePaper version of the INSPECT is mailed to 14,000 recipients worldwide. The German language printed version has a circulation of 20,000 issues.</p>
--	---	--	---



emva

european machine vision association

EMVA Business Conference 2010

8th European Machine Vision Business Conference
April 16th and April 17th, 2010, Istanbul, Turkey

International platform for networking and business intelligence.
Where machine vision business leaders meet.

www.emva.org

Golden Sponsor



Silver Sponsors



See the possibilities



EDIXIA inspection technology ensures **continual improvement** at each step of your process.

3dCast

Inspection of castings



The solution to all your requirements

Unsere Produkte:

3dCast-E

Cylinder head and engine block inspection system



3dCast-B

Brake disc inspection system

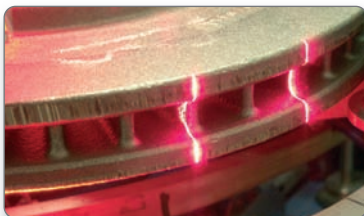

3dCast-Check

Multi-function 3D inspection machine



Discover **3dCast-Check**, our standalone non-destructive 3D inspection system for the inspection of each of the faces of raw or pre-machined castings.

3dCast-Check detects defects including, but not limited to: material voids, flashes and porosity.

3dCast-Check measures process defects including: mould misalignment, out of tolerance parts and geometric non-conformity of the part.

Inspection of **100 %** of the production to achieve significant quality improvement.
Traceability and **SPC tool** tracking individual mould numbers.